

KSBC150 Industrial Box Channel

The **KSBC150** channel is our most versatile and widely used channel system for all industrial floor finishes.

It is extensively used in **Food, Dairy, Beverage and Pharmaceutical** factories and - in grade 304 stainless as standard, often used in grade 316.

It is **customizable** - for higher flow rates, loadings or channel lengths than those listed below. Continuous runs of 200-100m are regularly supplied.

Features:

- 150mm wide body as standard with 25mm turnout and turndown each side
- 200mm outside edge to outside edge
- Used with either trapped 110mm or 160mm Gully outlet
- 50mm start depth
- 1:150 (0.06%) pre-sloped fall built in.

Applications/Industries

- ◇ Industrial
- ◇ Food
- ◇ Dairy
- ◇ Beverage
- ◇ Meat
- ◇ Pharmaceutical



OPTIONAL



GRATING OPTIONS

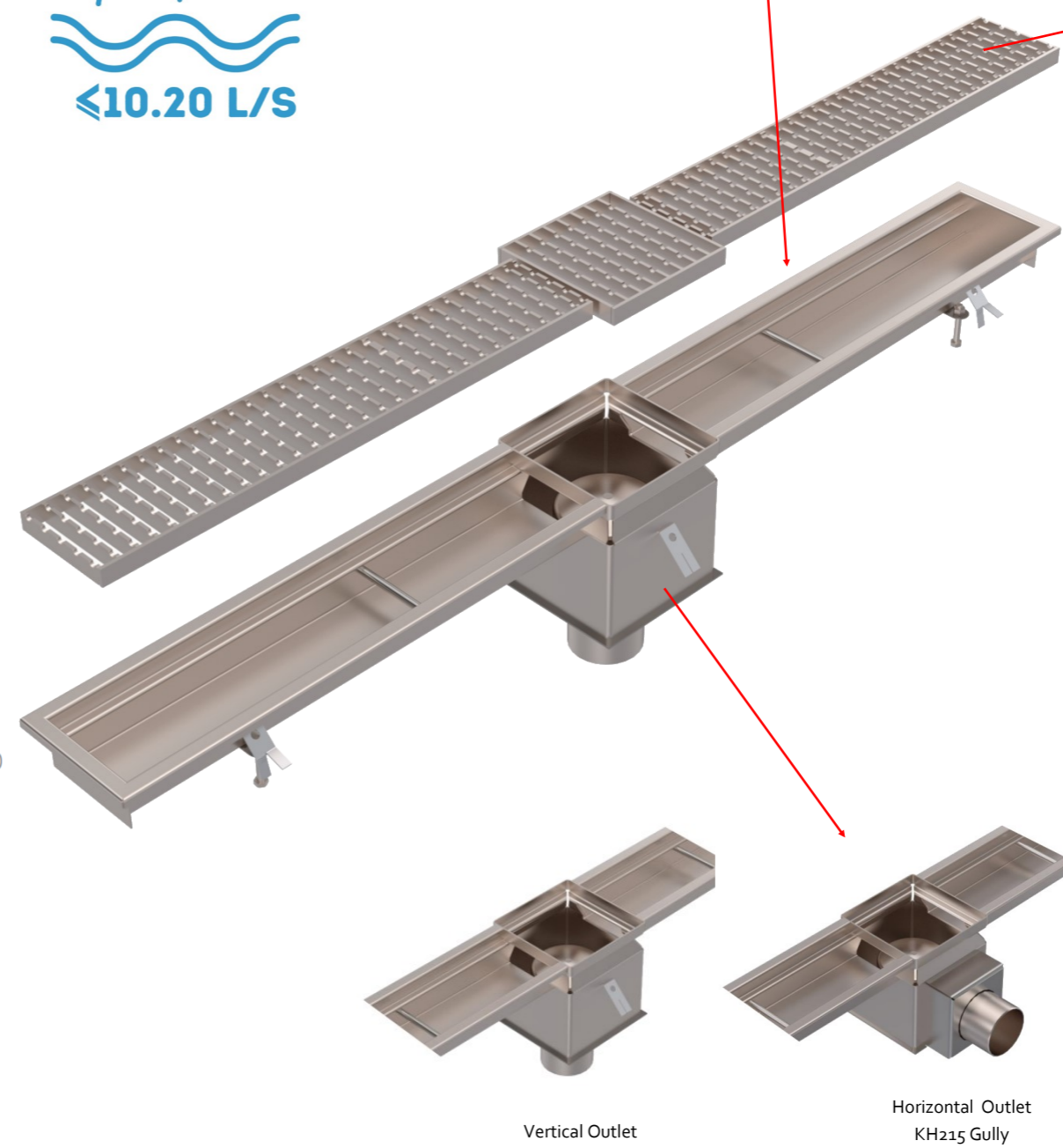
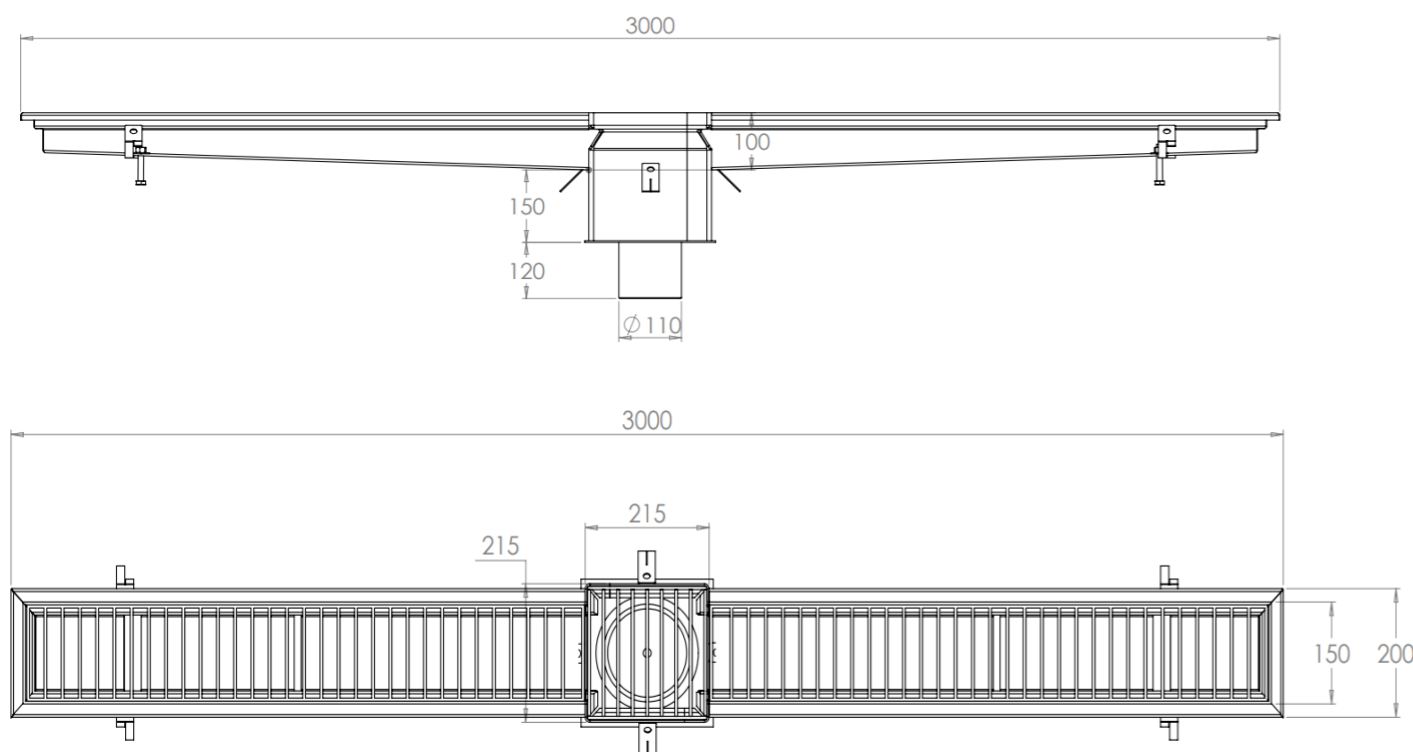
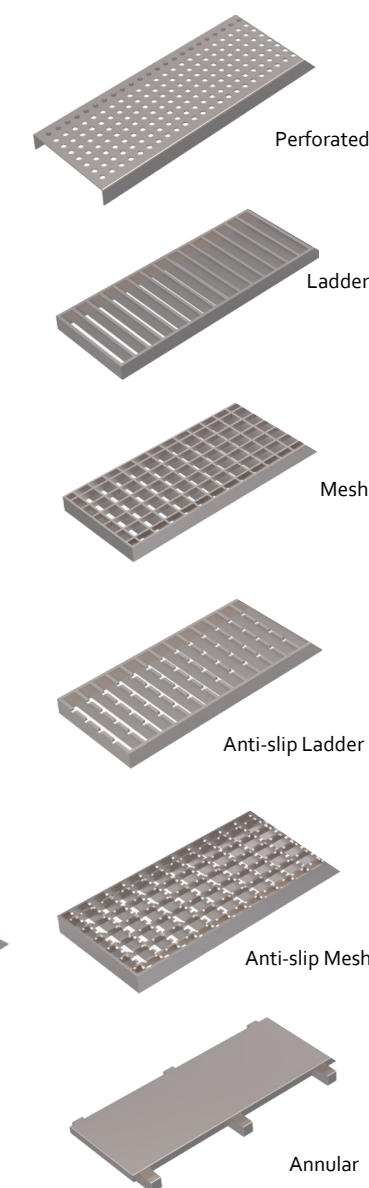

Vertical Outlet

Horizontal Outlet
KH215 Gully

Product Code	Min. start depth	Width	Outer Width	Outlet	Flow Rate
KSBC150/KV215-110	50	150	200	110	3.94 l/s
KSBC150/KH215-110	50	150	200	110	4.42 l/s
KSBC150/KV315-160	50	150	200	160	10.20 l/s
KSBC150/KH315-160	50	150	200	160	7.1 l/s

Specify: Kent Standard Box Channel KSBC150/KV215-110; to take 150mm wide grating; 3000mm long; Grade 304 Stainless Steel; Grating will be Kent Anti-Slip Ladder Grating Type; Load B125

(amend underlined words to suit project)

BS EN1433 Loading Class A15 / B125 / C250 / D400

Our internal channels can be subjected to very heavy loads but must have the correct heavy duty grating to achieve these loads. Suitable for Factories and Leisure Centres.