



CLEANROOM WALL MOUNTED BUMP RAILS



Cleanroom Wall Mounted Bump Rail

Kent Stainless Cleanroom Wall Mounted Bump Rails are ideal for use on projects with floors with coved corners, especially vinyl or altro floors and when a floor mounted solution is best avoided. This wall version also means cleaners have access to the full floor area and are not impeded by leg supports. They have tubular wall mount supports and usually end with a blanked off end plate. At doorways or near corners this can be changed for a bollard end which is floor mounted. The bump rail is typically surface mounted on circular baseplates with acorn head (dome nut) fixings. As an option it can have countersunk fixings.

Small to Medium sized projects in the USA & Canada will ship from East Coast USA.

Major international projects will ship from Ireland.

American projects are mostly made in the USA and made to imperial measures – typically a 2" dia tube. This same bump rail supplied to European projects would be supplied as a metric measure 48.3mm dia – rather than an exact conversion of 2" to 50.8mm. Approval drawings for each project will be supplied in imperial or in metric as requested and can be customised.

FEATURES

- 12GA (2.5mm) thick steel
- ASTM No. 6 Satin Finish (USA)
- EN10088 320 Grit Satin Finish (EU)
- Grade 304L Stainless Steel as standard
- 316L as an option
- Circular Wall Plates with Dome Nut Fixings
- Countersunk Fixings option available

INDUSTRIES

- Laboratories
- Pharmaceutical
- Hospitals
- Medical Facilities
- Biomedical

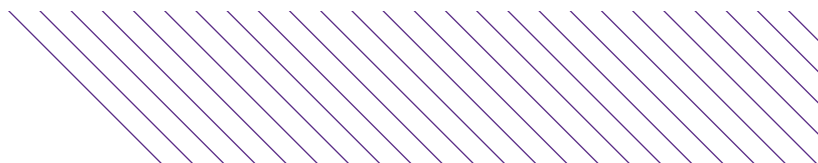
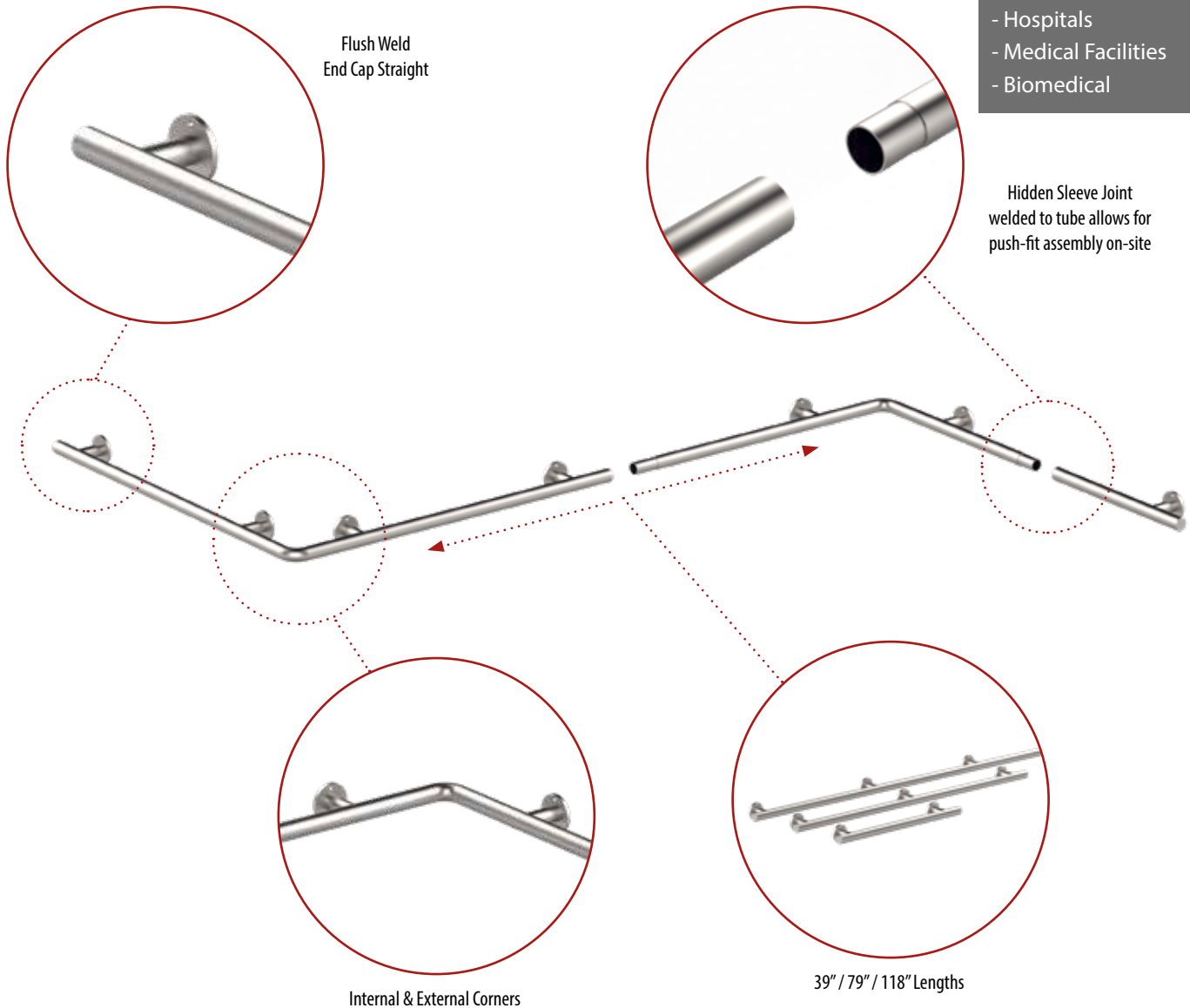

Product Code	Length	Offset	Diameter	
			USA	EU
Kent Cleanroom Wall Mount Bump Rail KWMBR-50	39.37" (1000mm)	4" (100mm)	2"	48.3mm
Kent Cleanroom Wall Mount Bump Rail KWMBR-50	78.74" (2000mm)	4" (100mm)	2"	48.3mm
Kent Cleanroom Wall Mount Bump Rail KWMBR-50	117.72" (2990mm)	4" (100mm)	2"	48.3mm

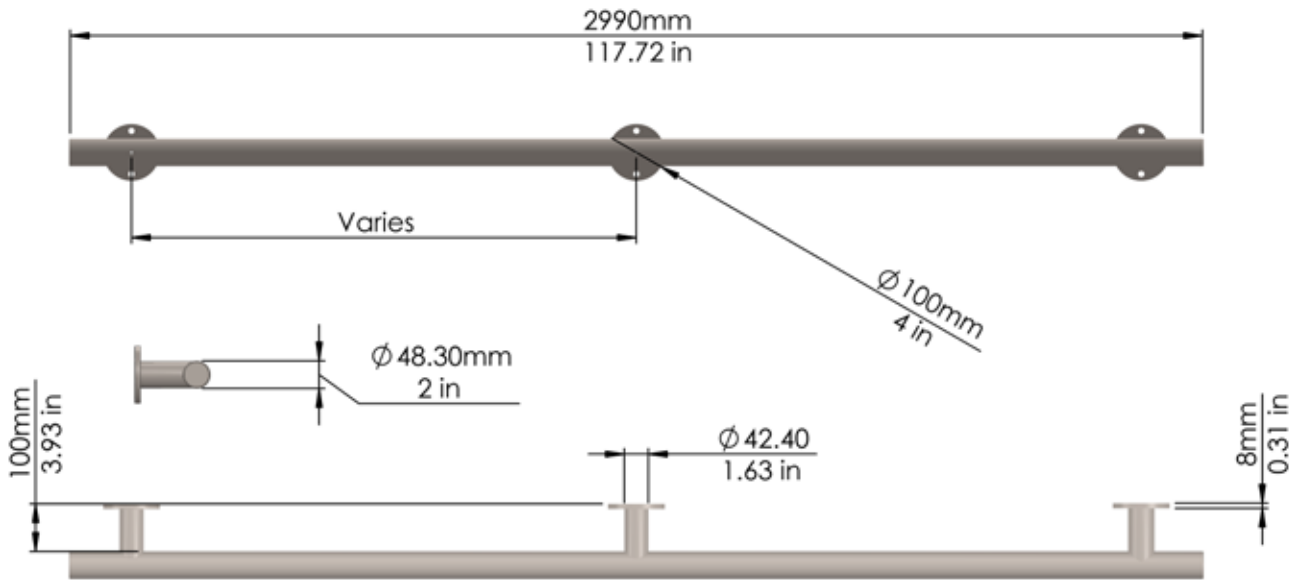

Optimal shipping length is 117.72" or 9.76' (2990mm) - custom lengths are regularly provided

START/END OPTIONS



Flat End



Bollard End

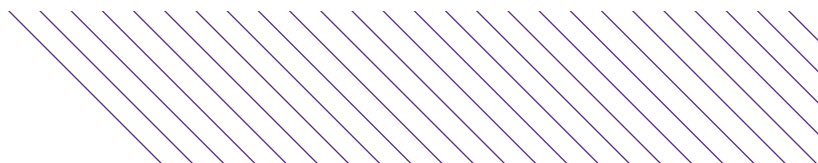

SPECIFY

Kent Cleanroom Wall Mount Bump Rail (KWMBR-50): ➤ Grade 304L Stainless Steel; ➤ ASTM No. 6 Polish (EN10088 320 Grit Satin Finish); ➤ L: 117.72" (2990mm), O: 4" (100mm). Dia: 2" (48.3mm); ➤ 12GA (2.5mm Thick Steel); ➤ Visible Wallplate with Dome Nut Fixings.

