

The KH215/110V Gully is the Vinyl Edge variation of our standard KH215/110 Side Outlet Gully. They are designed for use primarily in Commercial Kitchens with Vinyl Floors typically in Hospitals, Retail Outlets. They are low cost, normally ex stock.

While the construction of this gully body is heavy duty, in reality most vinyl floor areas are only trafficked by pedestrians so this is most often chosen with a pedestrian loading cover (Mesh or Perforated). The KH215/110V standard gully is best suited to 3mm thick covers that are made to sit in a 10mm recess (Perforated Gratings, Mesh and Ladder Gratings). The KH215/110DSV version of this gully (DS = Deep Swage) takes all 25mm deep gratings offered by Kent (most often Mesh, Heelproof Mesh Gratings).

In most cases a 110mm or 160mm outlet is required, but this can easily be substituted for a 4" or 6" SCH10 outlet pipe. It is trapped as standard with the Kent Weir Trap.

Features:

- Grade 304 (1.4301) or 316 (1.4401) Stainless Steel to BS EN 10088
- Low cost
- Strong
- Short lead time
- Usable in both heavy and light duty areas
- Suitable for Commercial Kitchen drainage and other areas using flexible flooring

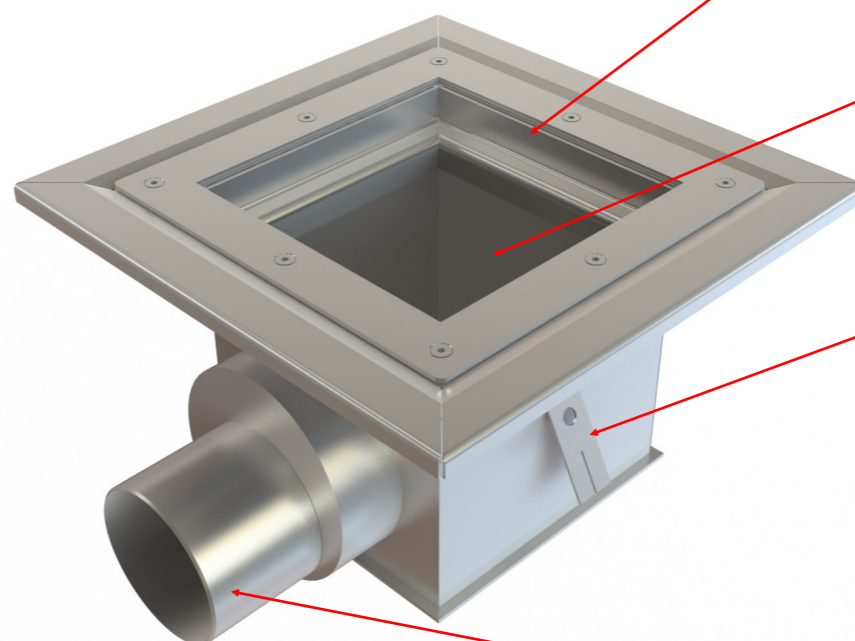
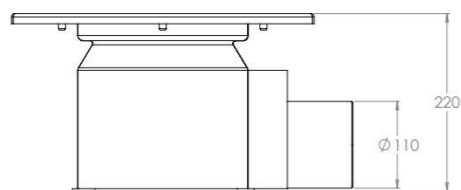
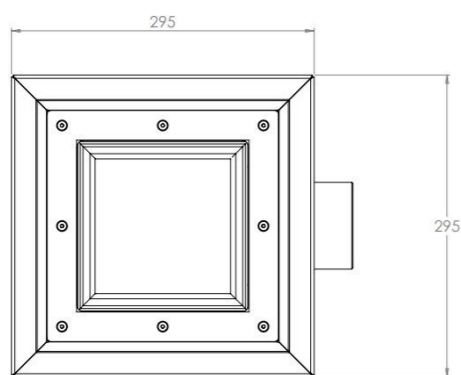

GRATING OPTIONS

FACTORIES

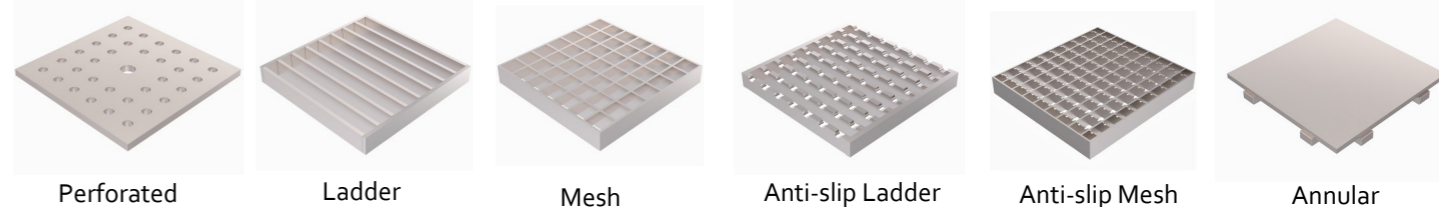

Perforated

Ladder

Mesh

Anti-slip Ladder

Anti-slip Mesh

Annular



Concrete Ties



Filter / Debris Basket

Product Code	Height	Width	Depth	Outlet	Swage	Flange	Flow Rate*
KH215/110V	220	215	215	110	10	40	4.42l/s
KH215/110DSV	235	215	215	110	25	40	4.75l/s
KH315/110V	220	315	315	110	10	40	4.42l/s
KH315/110DSV	235	315	315	110	25	40	4.75l/s
KH315/160V	269	315	315	160	10	40	9.10l/s
KH315/160DSV	284	315	315	160	25	40	9.85l/s

*flow rate is also dependent on grating chosen.

Specify: Kent KH215/110V trapped industrial side outlet gully for vinyl floor; 215mm x 215mm; grade 304 stainless steel; complete with _____ grating.

Choose the product code from the dimensions table above.

Add specification options from the next page.

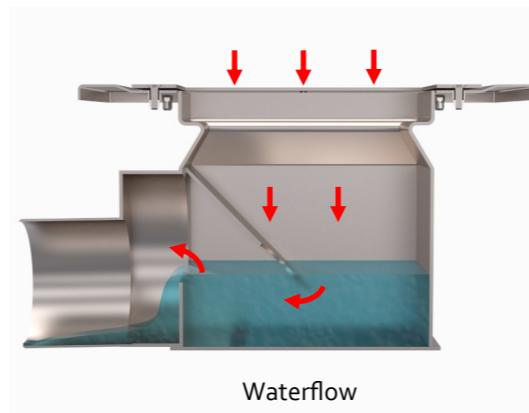

Waterflow



110mm side Outlet Pipe as Standard



4" SCH10 Pipe Optional

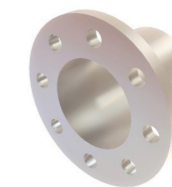

Flange Optional

BS EN1253 Loading Class L15 / R50 / M125 / N250 / P400

Our internal gullies can be subjected to very heavy loads but must have the correct heavy duty grating to achieve these loads. Suitable for Commercial Kitchens.