

The KVA205/110 Gully is a Round Body, Round Top/Bottom Outlet gully for heavy duty areas with high flow rates. It is adjustable height version of our KV220 gully and allows 60mm adjustment in height.

This is important when contractor may be uncertain of invert levels particularly in refurbishment projects. They are designed for use primarily in Food/Beverage/Pharmaceutical factories. They can be used in both light duty and very heavy duty trafficked areas (depending on the grating chosen). The KVA205/110 standard Gully takes 10mm thick gratings as well as 3mm thick covers that are made to sit in a 10mm recess (Perforated Gratings, Sealed Gratings).

The KVA205/110DS version of this gully (DS = Deep Swage) takes all 25mm deep gratings offered by Kent (Perforated, Factory Ladder, Heelproof Perforated and Slotted gratings). When used with Heelproof gratings it is suitable also for civil projects. In most cases a 110mm or 160mm outlet is required, but this can easily be substituted for a 4" or 6" SCH10 outlet pipe. It is trapped as standard with the Kent Bell Trap.

- Features:**
- Grade 304 (1.4301) or 316 (1.4401) Stainless Steel to BS EN 10088
  - Strong
  - Short lead time
  - Usable in both heavy and light duty areas
  - Suitable for internal factory drainage and external civil drainage projects

**GRATING OPTIONS**

**FACTORIES**



**STREETSCAPES**

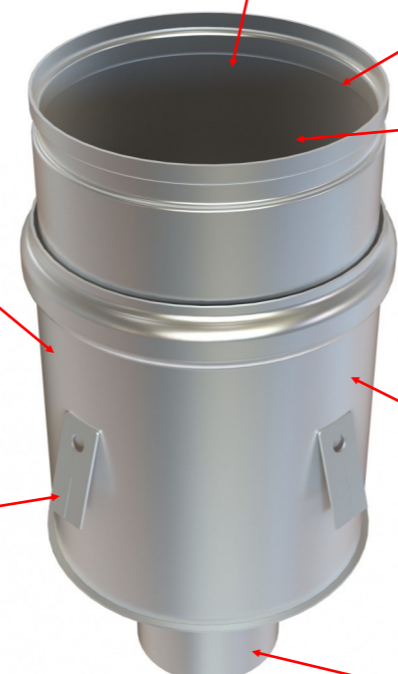
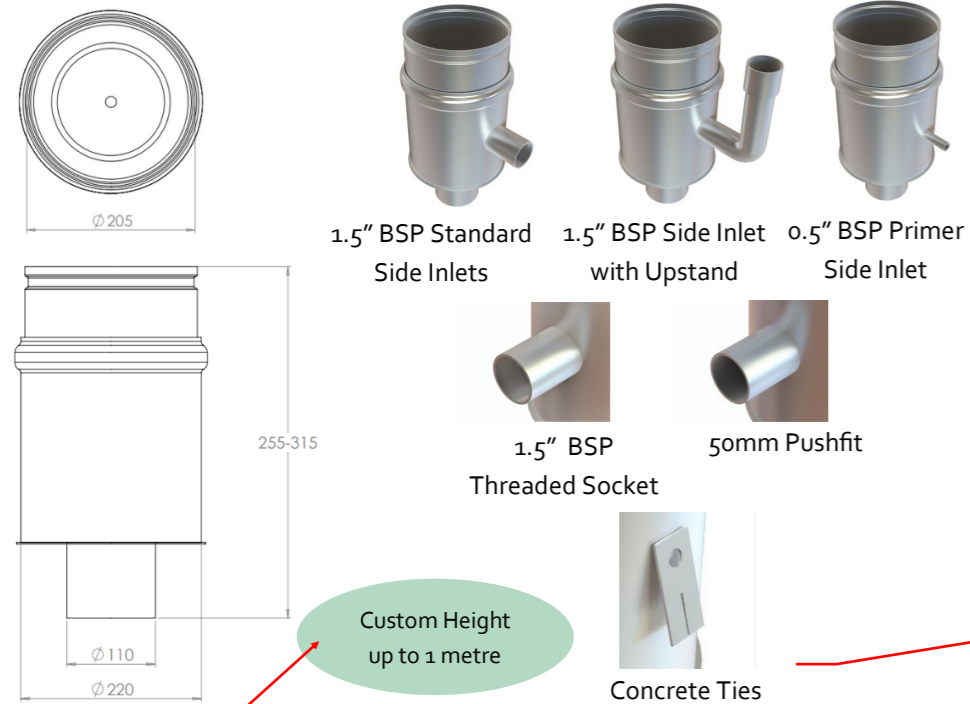

40mm wider Reinforced Edge Frame for Heavy Traffic

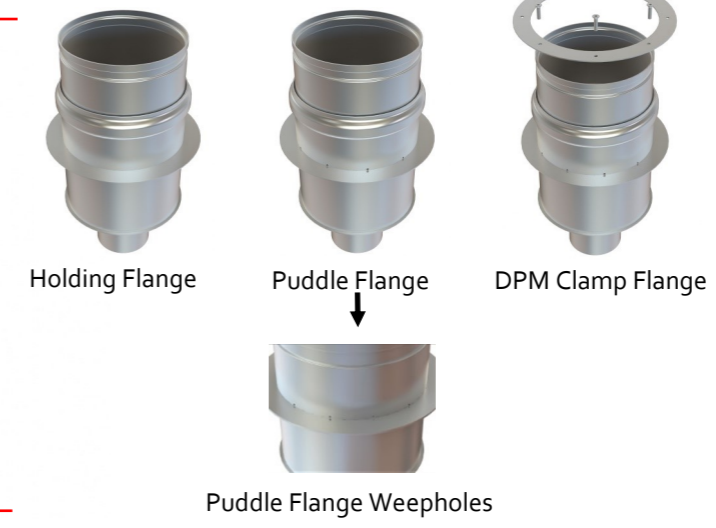

Product Code	Height	Top Diameter	Body Diameter	Outlet	Swage	Flow Rate*
KVA205/110	255-315	205/245	220	110	10	7.3l/s
KVA205/110DS	270-330	205/245	220	110	25	7.6l/s
KVA255/110	255-315	255/295	270	110	10	7.3l/s
KVA255/110DS	270-330	255/295	270	110	25	7.6l/s
KVA355/160	255-315	355/395	370	160	10	17.3l/s
KVA255/110DS	370-330	355/395	370	160	25	18.2l/s

\*flow rate is also dependent on grating chosen.  
 Specify: Kent KVA205/110 trapped industrial gully; 205mm diameter; grade 304 stainless steel; complete with \_\_\_\_\_ grating.  
 Choose the product code from the dimensions table above.  
 Add specification options from the next page.

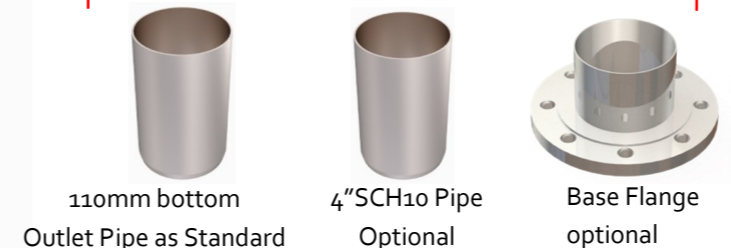

**BS EN1253 Loading Class L15 / R50 / M125 / N250 / P400**  
 Our internal gullies can be subjected to very heavy loads but must have the correct heavy duty grating to achieve these loads. Suitable for Factories and Leisure Centres.  
 (BS EN1253 Gullies & Buildings)

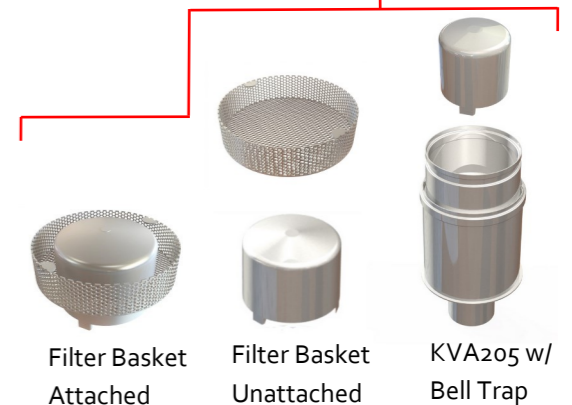

**BS EN124 Loading Class A15 / B125 / C250 / D400**  
 Our external gullies can be subjected to very heavy loads but must have the correct heavy duty grating to achieve these loads. Suitable for Streetscapes.  
 (BS EN124 Gullies for Vehicular & pedestrian areas)