



# Smiley Bollard



# Kent

## Smiley Bollard

### KDCT-101/3

#### Specify:

Kent Smiley Bollard KDCT-101/3; 1200mm Overall Height; 3mm thick wall; Grade 316L Stainless Steel; Shot Peened Body, Satin finish; Cast in 300mm below the ground.

The Kent Smiley Bollard is manufactured from Grade 316L Stainless Steel, 101mm diameter with a 3mm thick wall. It has a Shot Peened Body, Satin finish as standard. The standard length is 1200mm, with 300mm being cast below ground, giving 900mm above ground. It has laser-cut cut pull out sprags, along with perforation to receive the lock from a removable socket. This means this one bollard can be used as a fixed bollard or it can be easily made removable with a NAL/IPL socket.



#### Features

- Shot Peened Body, Satin Finish
- 3mm wall thickness
- Grade 316L Stainless Steel
- Laser cut pull out sprags
- Stamped Kent Logo

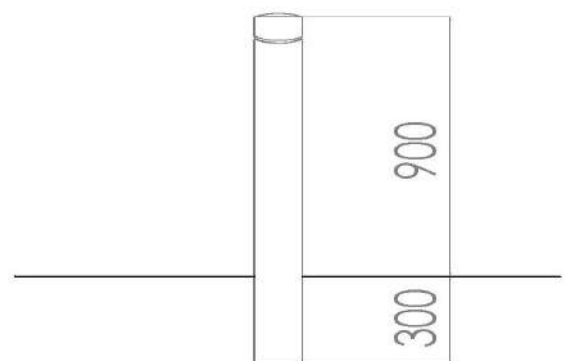



**Product Dimentions:**

Reference	Height	Diameter	Thickness
Kent Smiley Bollard KDCT-101/3	1200mm	101mm	3mm
Kent Smiley Bollard KDCT-114/3	1200mm	114mm	3mm
Kent Smiley Bollard KDCT-141/3	1200mm	141mm	3mm
Kent Wembley Bollard KFT168/3	1200mm	168mm	3mm

## **Bollard Installation**

### **Visible Flange:**

- Ensure that the surface to which the bollard is mounted is sufficiently strong.
- Position the bollard in the correct location. Mark the holes and drill into the surface.
- Place the bollard directly over the holes and then fix the bollard to the surface using M12 bolts.
- Note that fixings need to be fully embedded in concrete not just the paver blocks.
- Always consult with the engineers specifications—we recommend a minimum of 2 times the root length.

### **Buried Flange:**

- Cast foundations—always consult with engineers specifications—we recommend a minimum of 2 times the buried root length ( $300\text{mm} \times 2 = 600\text{mm}$ ) and times the bollard diameter (eg  $3 \times 101\text{mm} = 303\text{mm}$ ).
- Once concrete is set follow steps 1-3 as per flange detail above.
- Replace slabs to finish off bollard.

### **Cast In:**

- Cast foundations—always consult with engineers specifications — we recommend a minimum of 2 times the buried root length ( $300\text{mm} \times 2 = 600\text{mm}$ ) and 3 times the bollard diameter ( $101\text{mm} \times 3 = 303\text{mm}$ ).
- Position your bollard in the correct position ensuring correct height and then prop the stand securely. Fill the hole with concrete up to the level of the underside of the pavement ensuring a good smooth surface finish.
- Remove props, replace the paving slabs and ensure that they are well bedded in.

For Ram Raid bollards again use consulting engineers specification. Kent recommends minimum of 4 times the buried root length ( $300\text{mm} \times 4 = 1200\text{mm}$ ) and 6 times the diameter ( $101\text{mm} \times 6 = 606\text{mm}$ ).

### **Removable Hidden Lock Socket and Removable Flip Lid Socket**

- Remove pavement in the location the bollard will be placed. Excavate a hole of minimum  $400\text{mm LxWxD}$ .
- Place socket of bollard into the hole ensuring the top surface of the socket meets the top surface of the pavement.
- Fill the hole with concrete leaving sufficient space for pavement.

When set finish off pavement around socket and place bollard into the sock

**Product Options:**

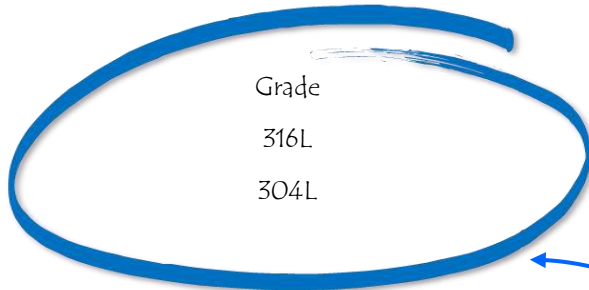

**Specify:**

Kent Smiley Bollard KDCT101/3; 1200mm Height; 3mm thick wall; Grade 316L Stainless Steel; Shot Peened Body, Satin Finish; Cast in 300mm below the ground.



# Kent Smiley Bollard KDCT-101/3

## Overview

The Kent Smiley Bollard KDCT-101/3 is constructed from 316L Stainless Steel with a 3mm thick body. The external finish of the bollard is a Shot Peened Body, Satin Finish. Despite the material's corrosion resistant properties some care is required to maintain a bright appearance. The conditions that the bollard is in (Inland or Coastal area), will greatly increase its need for cleaning and care.

## Maintenance

### Stainless Steel:

Clean the stainless steel components using warm water with a mild detergent with a non-abrasive cloth or sponge. Heavier stains may require the use of a nylon-scouring pad or a stainless steel cleaner. To remove paint or graffiti use a cloth and Alkaline or solvent paints and strippers according to type of paint. In the case of a bead blasted finish, where abrasive cleaning is required, always use a random circular rubbing action with a cloth. In the case of brushed finishes the surface consists of uniform fine 'scratches' running in one direction so where abrasive cleaning is required always use a straight back and forward rubbing action in the direction of the grain using soap and warm water. Rust spots or tea stains can occur on the surface of the material, these are normally caused by contamination from ordinary mild steel, particularly in areas where construction work has been undertaken. Such stains can be removed using Rust Remover 410. In cases where the surface is severely stained because of severe environmental conditions or scratched due to misuse, it may still be possible to restore the original finish using chemicals such as Oxalic Acid solution. There are many stainless steel polishes available to enhance the surface finish. We recommend Mister Stainless Ltd. As a provider for stainless steel products.



## Our Range of Bollards

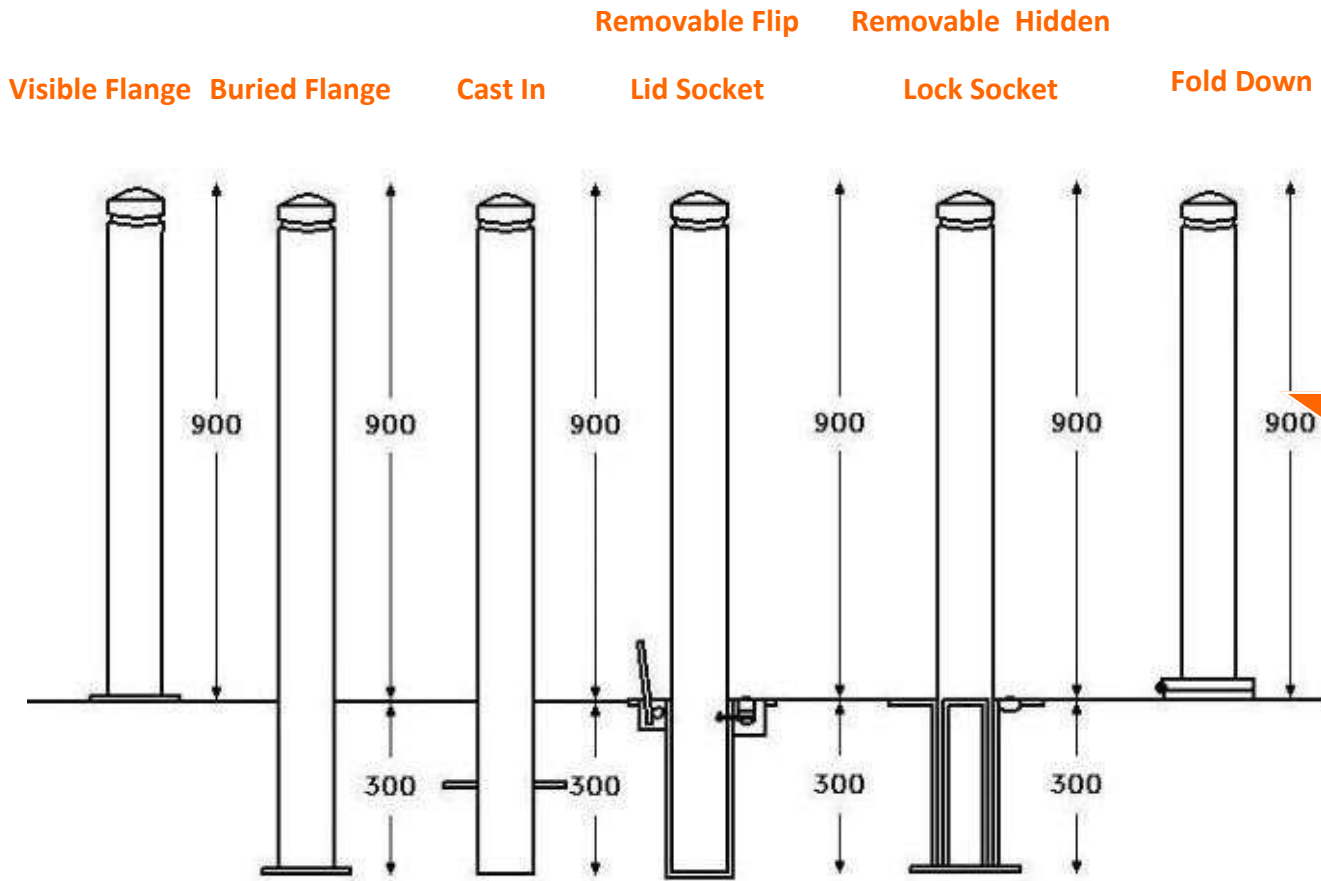





**Kent Smiley Bollard**  
**KDCT-101/3**

