

The KVT152 Gully is a square top stainless steel gully for tiled and poured floor areas. It is supplied as standard with a lockdown slotted grating. It has a heavier duty top than our KVT162 and can take heavier traffic. The Foul Air Trap comes as standard with an optional Strainer.

The Height Adjustment Version, both bottom outlet and side outlet, allows for optional flanges and side inlets to be included, simply specify any additional modifications required

This is an ideal drain for areas of intense pedestrian activity such as a stadium, railway station, airport or supermarket. Locations where pallet truck traffic is expected will also suit this drain.

- Features:**
- Grade 304 (1.4301) or 316 (1.4401) Stainless Steel to BS EN 10088
 - Satin finish as standard
 - Customised perforated patterns available
 - Ex stock
 - Lock down as standard

This aesthetic 'chunky' slotted grate is the perfect fit for areas of intense pedestrian traffic with design at the forefront.

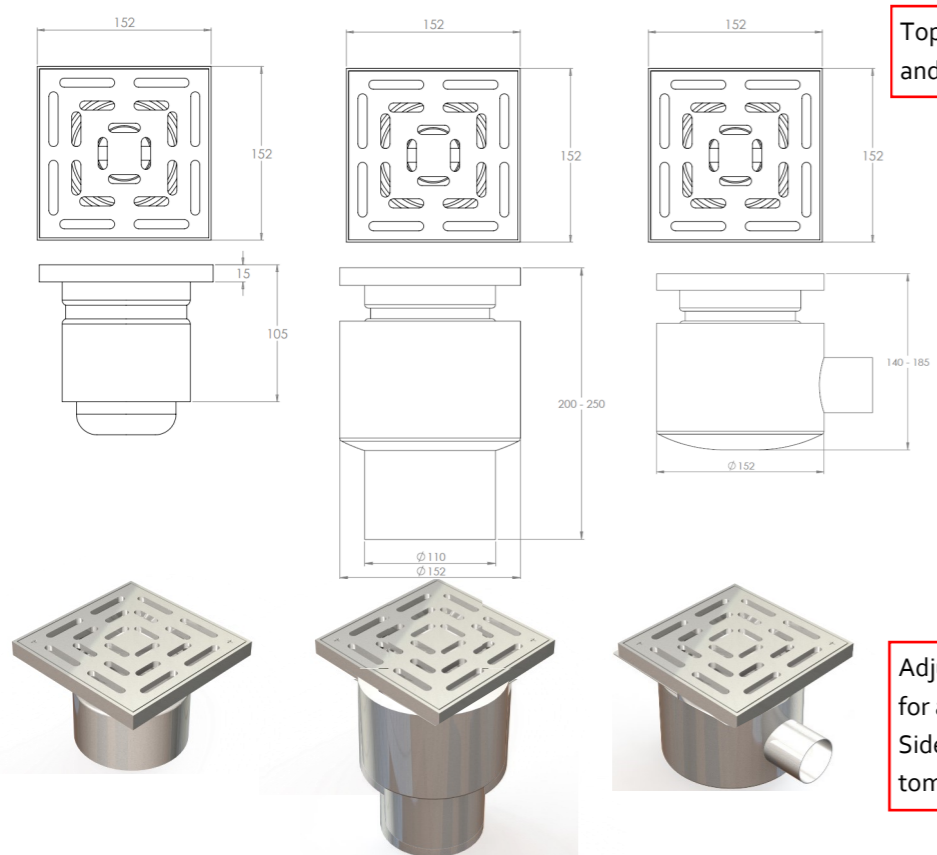
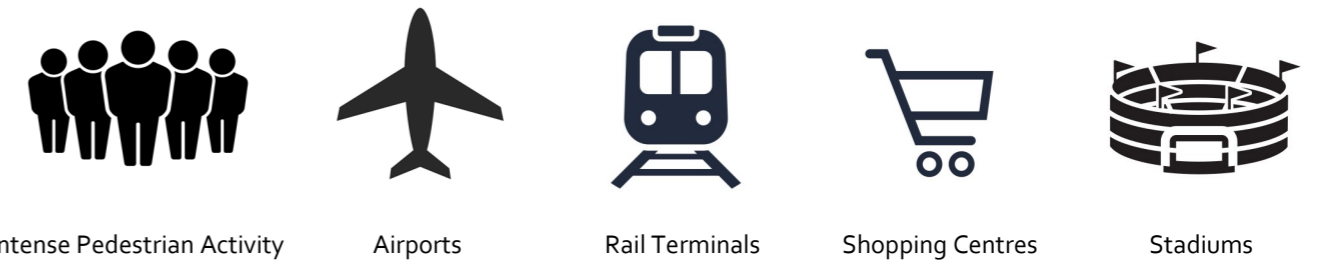

Top Part with Slotted Grate and Foul Air Trap as standard



Adjustable Height body allows for addition of Flanges and Side Inlets and choice of Bottom/Side outlet

Top Part Only Adjustable Height Bottom Outlet (KVBO Body) Adjustable Height Side Outlet (KHBO Body)

| Product Code | Height | Width | Depth | Outlet | Flow Rate* | Description |
|----------------|---------|-------|-------|---------|------------|--|
| KVT152/110TP | 105 | 152 | 152 | 110 | 1.4l/s | Top Part Only Bottom Outlet 110mm |
| KVT152/110 | 200-250 | 152 | 152 | 110 | 1.4l/s | Adjustable Height 2 Part Bottom Outlet |
| KHT152/50 | 140-185 | 152 | 152 | 50 | 0.9l/s | Adjustable Height 2 Part Side Outlet 50mm |
| KHT152/1.5"BSP | 140-185 | 152 | 152 | 1.5"BSP | 0.9l/s | Adjustable Height 2 Part Side Outlet 1.5"BSP |
| KFT110 | | | | | | 110mm Trap with 50mm water seal |

Specify: Kent KVT152/110TP Floor Gully. 152mm x 152mm, fixed/adjustable height floor drain. Grade 304 stainless steel with a satin polish finish, supplied with KFT110 Trap.

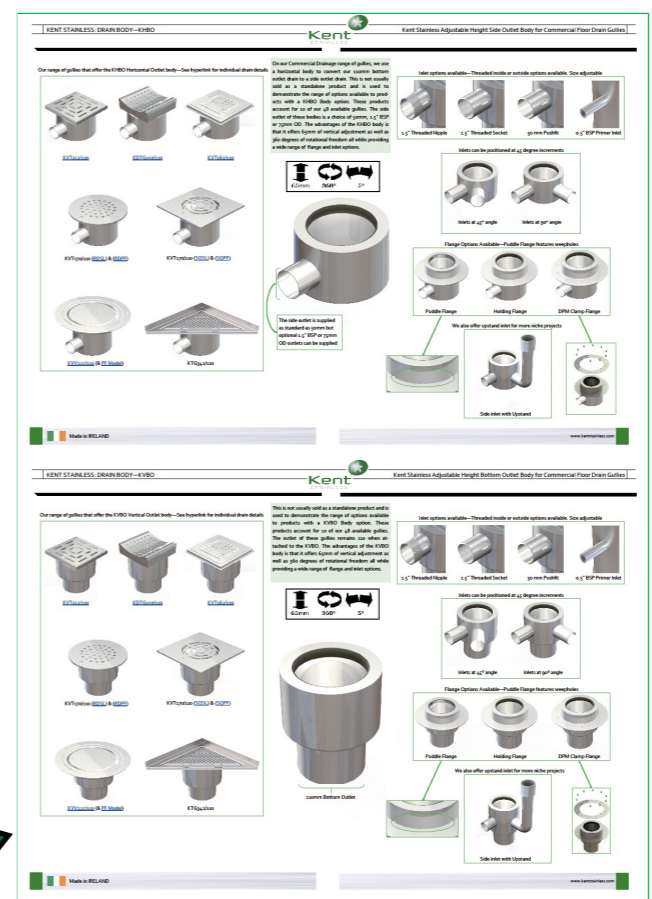
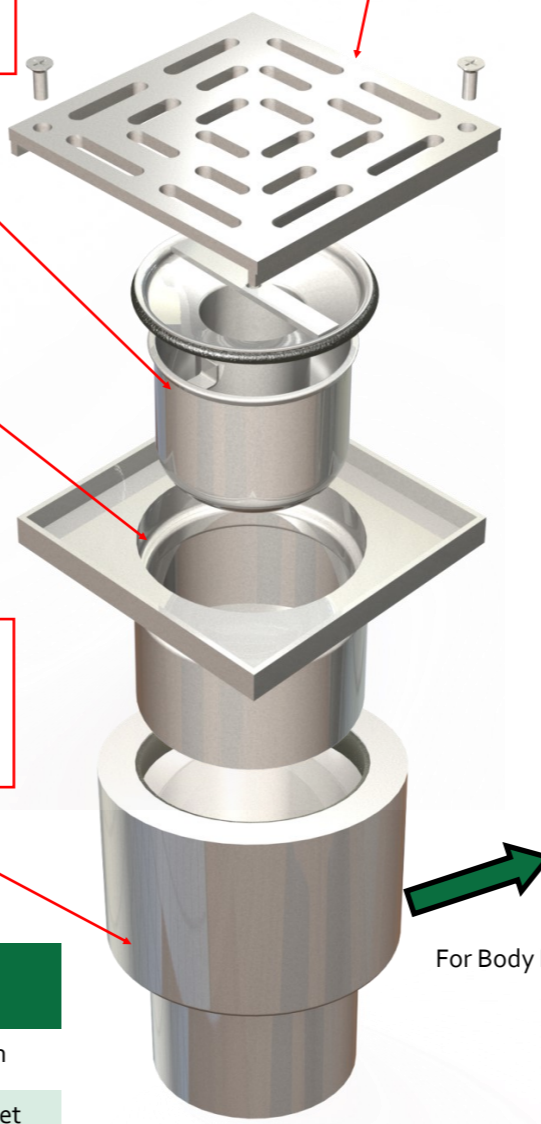

For Body Modifications, see the KVBO and KHBO Product Pages

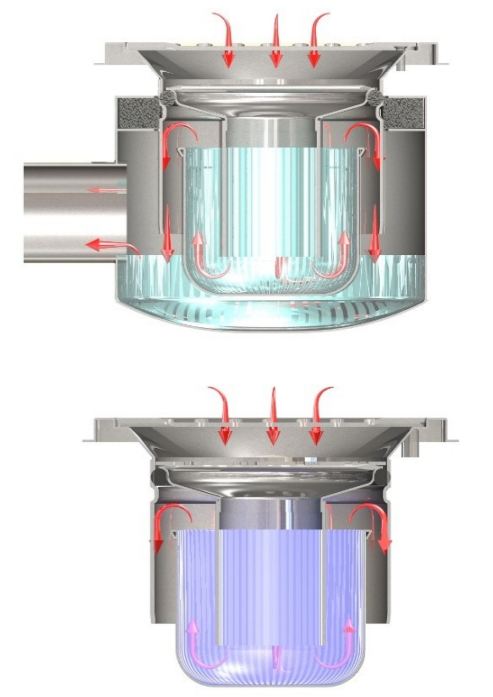

Waterflow for Adjustable Height Bodies

BS EN124 Loading Class A15 / B125 / C250 / D400
 Our external gullies can be subjected to very heavy loads but must have the correct heavy duty grating to achieve these loads. Suitable for Streetscapes.
 (BS EN124 Gullies for Vehicular & pedestrian areas)

BS EN1253 Loading Class K3 / L15 / R50 / M125 / N250 / P400
 Our internal gullies can be subjected to very heavy loads but must have the correct heavy duty grating to achieve these loads. Suitable for Commercial Kitchens.
 (BS EN1253 Gullies & Buildings)