



Kent Norman Way Cycle Stand



Kent Norman Way Cycle Stand KNWC-600/800

Specify

The Kent Norman Way Cycle Stand (KNWC 600/800); Grade 304 Stainless steel; Powdercoated RAL9007;

Description

The Kent Norman Way Cycle Stand (KNWC 600/800) is an 800mm wide by 600mm high stainless steel cycle stand with a powder coated RAL9007 finish as standard. The Cycle stand is manufactured from heavy duty grade 304 stainless steel throughout to maximise vandal resistance and minimise maintenance. The vertical end posts come with cycle symbols or a customised logo on either end as standard. The design allows two bicycles to be locked in position. The cycle stands can be found on the Norman way route throughout Wexford and Waterford.

Features:

- Grade 304 Stainless Steel
- Customised logo
- Powdercoated RAL9007 Finish
- Cast in

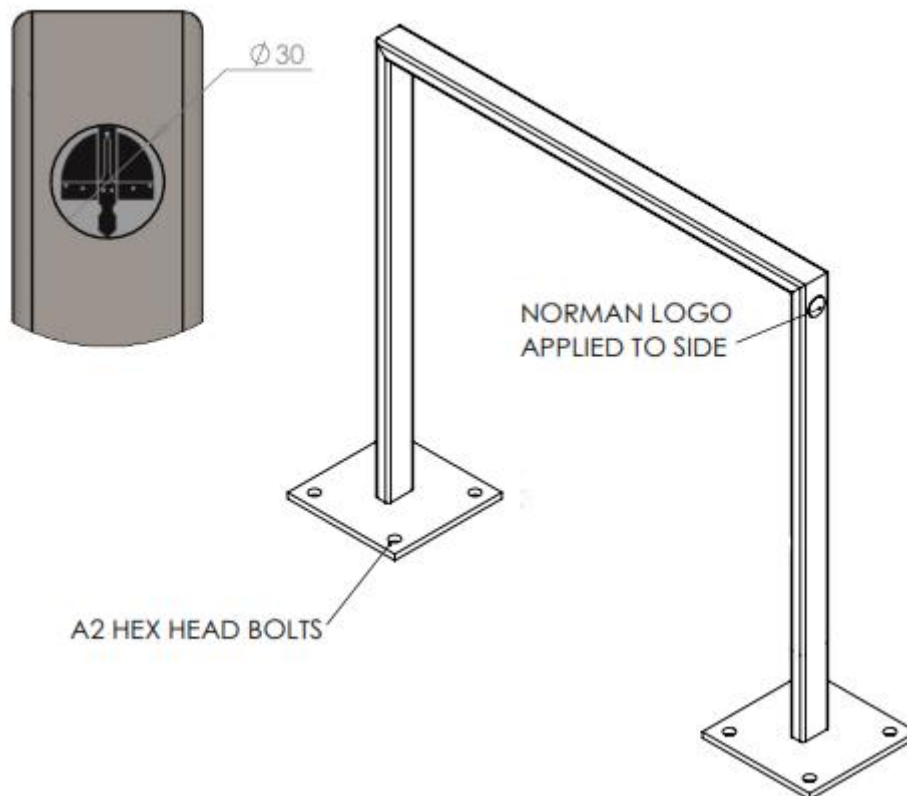

Kent Norman Way Cycle Stand KNWC-600/800

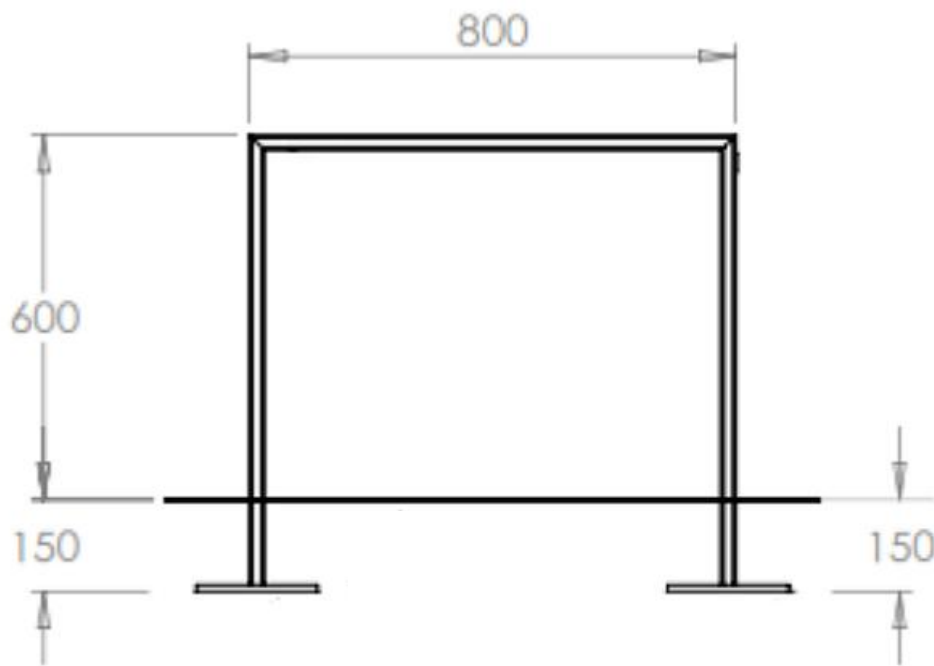

Product Dimensions:

Reference	Height	Width	Post Width
Kent Norman Way Cycle Stand	600mm	800mm	50mm x 20mm



Kent Norman Way Cycle Stand KNWC-600/800

Maintenance

How often?

For an area that receives regular rainfall that washes away the build up of salt deposits, cleaning should be done once a year. If rainfall cannot get to certain areas, but still salt and pollution deposits can blow onto it (e.g. the underside of a tram shelter) then cleaning should be done 1-2 times a year in urban environments and 3-4 times a year in marine environments. In a particularly severe environment with pollution and salt deposits and wind with little rainfall, cleaning should be done 4-12 times per year.

Judge your cleaning regime by the nearby glass panels or window cleaning and clean the stainless as often as the glass nearby.

How do I do it?

For regular cleaning, and for a preventative regime, a simple wipe down by soft cloth or sponge with a mild detergent is enough (e.g. 5% dilution of wash-up liquid). Rinse off with de-ionised water or bottled drinking water is fine if this is not readily available. Rub dry with a clean dry cloth rather than letting the product drip dry.

If staining does not disappear, switch the soft cloth to a pad of Scotchbrite™ from 3M™. Use the soapy water with Scotchbrite™ vigorously on areas that are unpolished or not architecturally important. For polished areas of products with a grain (e.g. Satin Finish 320 Grit Polish), rub gently forwards and backwards only in the direction of the grain direction so proceed with caution if this is an architecturally important feature.

Again – rinse with de-ionised water and dry with a soft cloth. For heavier staining or contamination by iron products Kent recommend Avesta cleaning chemicals. Cleaner Avesta 401™ can be used instead of the mild detergent as above. Avesta 420™ Fingerprint remover is a good cleaner to for areas prone to public fingerprints – it must be sprayed on and rubbed in while wet.

Pickling Gel Avesta 130™ (hazardous) and Passivator Avesta 630™ can be used for large, important features, but these should be discussed and a method statement is available from Kent Stainless for their use. This work can be sub-contracted to Mister Stainless™ in Ireland and Edimex™ in Dubai.

Kent Norman Way Cycle Stand KNWC-600/800

Visible Flange:

- Ensure that the surface to which the stand is mounted is sufficiently strong.
- Position the pole in the correct location. Mark the holes and drill into the surface.
- Place the pole directly over the holes and then fix the pole to the surface using M12 bolts.

Buried Flange:

- Cast a foundation with a minimum dimension of L350 x W350 x D350mm below the surface.
- Once concrete is set follow steps 1-3 as per flange detail above.
- Fill hole with grout and replace slabs to finish of the pole

Cast In:

- Remove pavement and excavate a hole to minimum dimensions of L350 x W350 x D350mm.
- Position your pole in the correct position ensuring correct height and then prop the stand securely.
- Fill the hole with concrete up to the level of the underside of the pavement ensuring a good smooth surface finish..
- Remove props, replace the paving slabs, and ensure that they are well bedded in



**Kent Norman Way
Cycle Stand
KNWC-600/800**



**Kent Norman Way
Cycle Stand
KNWC-600/800**

