

The Kent KV265/110 Fixed Height Gully is a 'Box Top' version of our KV215 family of square body gullies. The edge profile allows for ingress of concrete or resin under the turn-out and also this area can be re-enforced with stainless box section or solid bar for very heavy duty applications.

They are designed for use primarily in Food/Beverage/Pharmaceutical factories. They are used in both light duty and very heavy duty trafficked areas (depending on the gratings chosen). The KV265/110 has a 25mm deep grating seat and so takes all Kent Mesh, Factory Ladder plus our 3mm and 10mm perforated gratings can be modified to sit in the 25mm recess.

In most cases a 110mm or 160mm outlet is required, but this can easily be ordered with a 4" SCH10 or 6" SCH10 outlet pipe. It is trapped as standard with the Kent Bell Trap.

Features:

- Grade 304 (1.4301) or 316 (1.4401) Stainless Steel to BS EN 10088
- Low cost
- Strong
- Short lead time
- Usable in both heavy and light duty areas
- Suitable for internal factory drainage

GRATING OPTIONS

FACTORIES

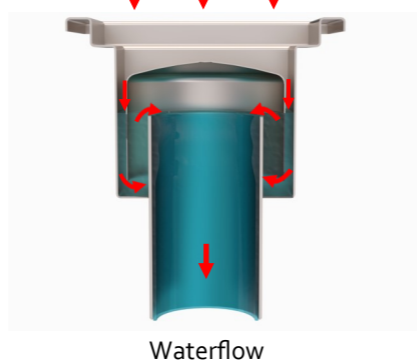
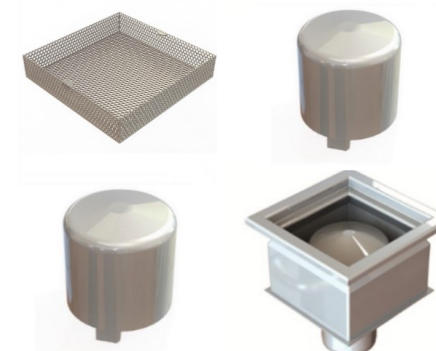
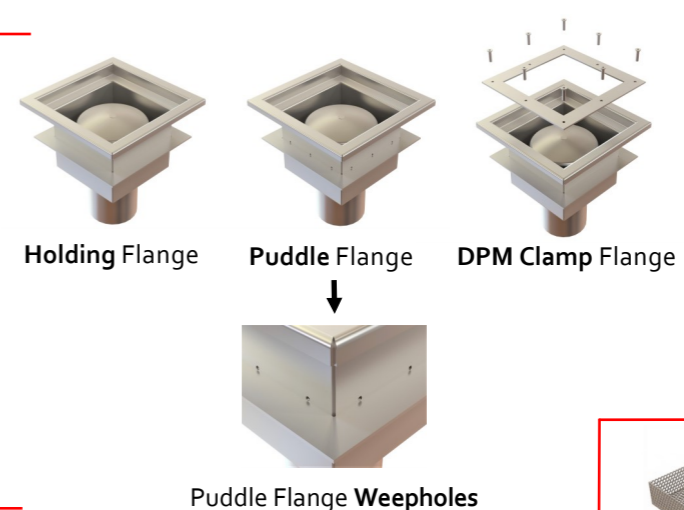
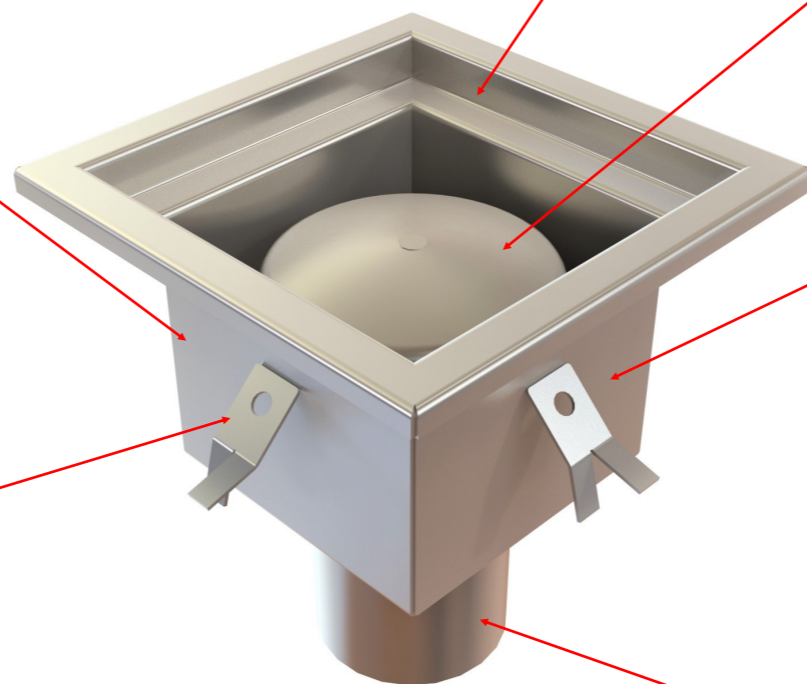
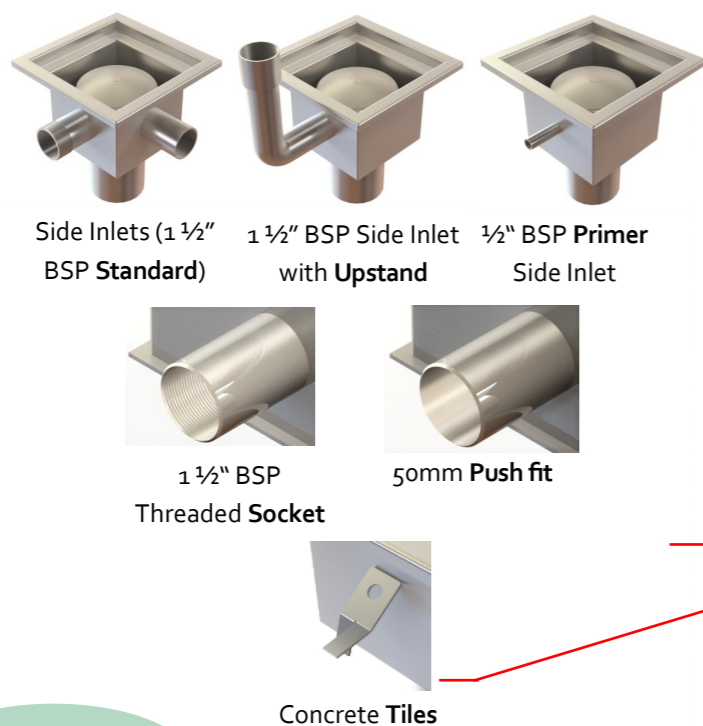
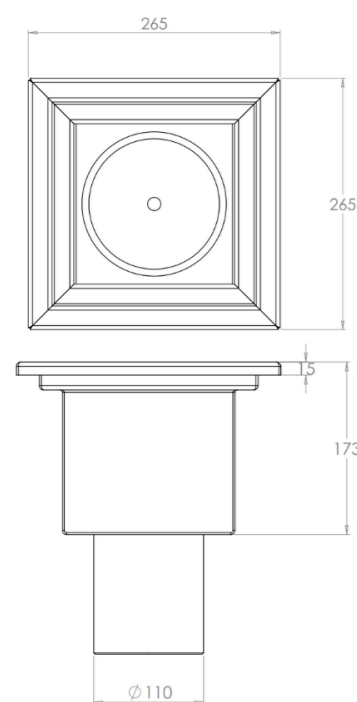
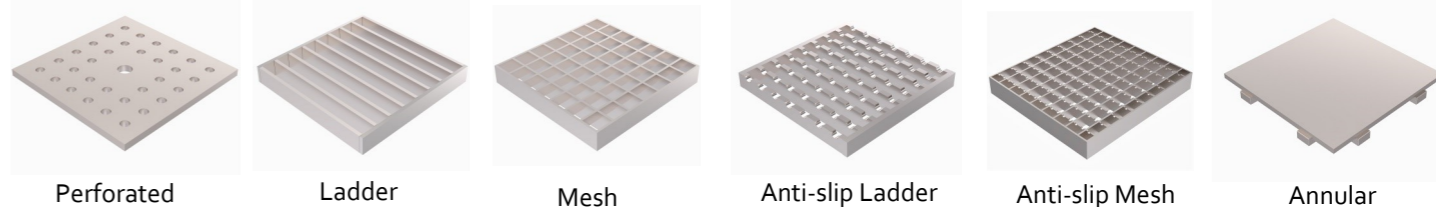

Custom Height up to 1 metre

Product Code	Height	Width	Depth	Outlet	Swage	Flow Rate*
KV265/110	173	265	265	110	25	4.34 l/s
KV365/110	173	365	365	110	25	4.34 l/s
KV365/160	203	365	365	160	25	11.70 l/s

*flow rate is also dependent on grating chosen.

Specify: Kent KV265/110 trapped industrial gully; 265mm x 265mm; grade 304 stainless steel; complete with _____ grating.

Choose the product code from the dimensions table above.

Add specification options from the next page.

BS EN1253 Loading Class L15 / R50 / M125 / N250 / P400

Our internal gullies can be subjected to very heavy loads but must have the correct heavy duty grating to achieve these loads. Suitable for Factories and Leisure Centres.