

Roma Bin

Nov 2023





STREET FURNITURE

Roma Bin

DESCRIPTION

The Kent Roma Bin is a 75 litre, stainless steel litter bin. This is one of our budget products – but it is still made from Grade 316L Stainless Steel. The bin has a simple, practical unobtrusive design as it was designed not to stand out, but rather blend into the surrounding landscape. As standard it comes with a 'Tidyman' decal on the vertical front panel. It also has lasercut lettering on the top horizontal surface indicating litter type.

FEATURES

- Grade 316L Stainless Steel
- Fire resistant galvanised liner
- Heavy duty stainless steel slam lock
- Heavy duty full length piano hinge
- Vandal resistant 3mm thick stainless steel



Bus Station, Portsmouth, UK

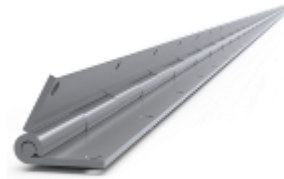

Piano Hinge



Slam Lock



Fire resistant galvanised liner

PRODUCT DIMENSIONS

Reference	Height	Width	Depth
KRB400	850mm	400mm	85 litres
KRB500	850mm	500mm	120 litres

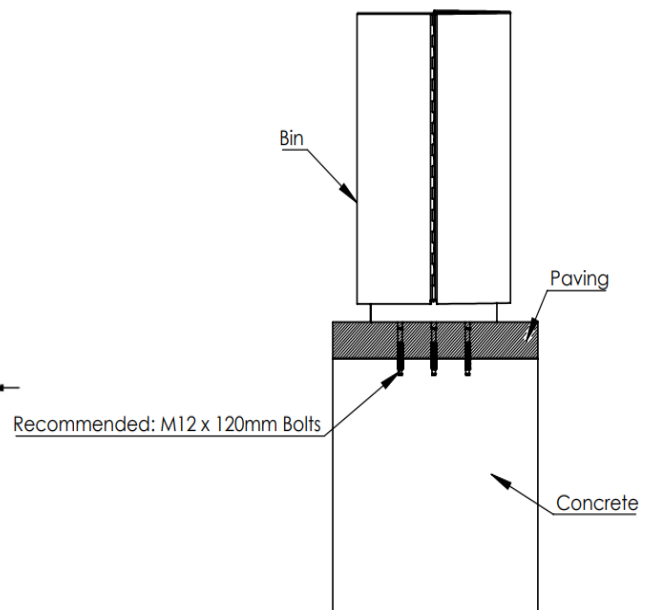
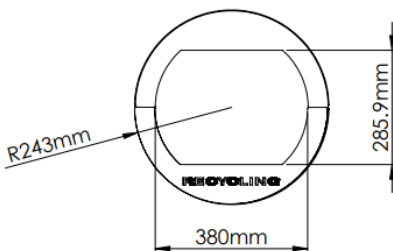
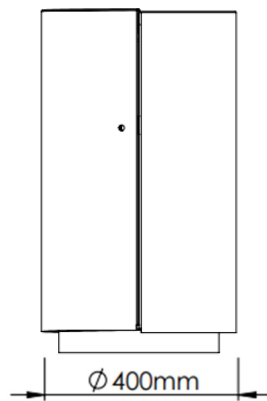
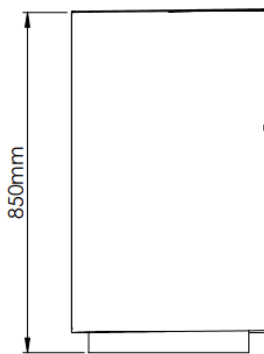

500x550x700 Foundation

Roma Bin



Brixton, High Road, London

Specification

Choose your capacity
85l or 120l depending on the
size of your bin

Choose your steel:

Grade 304 Stainless steel
Grade 316 Stainless steel

Specify:

Kent Roma Litter Bin KRB400;
400mm Diameter; 85 Litre Capacity; Grade 316L Stainless Steel; 3mm Thick Wall; Bright Satin Finish; Surface Mounted. Include 'Litterman Symbol' Decal;

**Customise your size, or go with
our standard 400mm/500mm
Sizes**

Choose your Decals;
Litterman
Recycling Symbol
Recycle Text
Custom Branding

Choose your Finish

Bright Satin
320 Grit Satin Finish
Bright Peened
Shot Peened
Tiger Bronze
Imitation Corten
Antique Copper
Metallic Black

Installation of Litter bins:

Ensure that the surface to which the bin is mounted is sufficiently strong.

Position the bin in the correct location. Mark the holes and drill into the surface

Place the bin directly over the holes and then fix the bin to the surface using M12 bolts.

There are 4 fixing points on the base for fitting to the ground using anchoring bolts

A typical foundation would be 750mm x 550mm x 550mm of 35N20 concrete - but this is the responsibility of the site engineer's specification

For Paved Areas:

Length of the M12 bolts will depend on the depth of the paver blocks plus bedding. For example, with 60mm deep paver blocks plus 20mm deep bedding, we recommend M12 X 180MM

For Non Paved areas:

M12 x 120mm bolts are recommended



Roma Bin



Stainless



Faux Imitation Corten



Tiger Bronze



Bright Peened



Bright Satin



Satin Finish 320 Grit Polished



Shot Peened



Tiger Bronze



Imitation Corten



Antique Copper



Metallic Black



Click on Finish image
for further information

CLEANING & MAINTENANCE

Clean the stainless steel components using warm water with a mild detergent with a non-abrasive cloth or sponge. Heavier stains may require the use of a nylon-scouring pad or a stainless steel cleaner.

To remove paint or graffiti use a cloth and Alkaline or solvent paint strippers according to type of paint. In the case of a bead blasted finish, where abrasive cleaning is required, always use a random circular rubbing action with a cloth. In the case of brushed finishes the surface consists of uniform fine 'scratches' running in one direction so where abrasive cleaning is required always use a straight back and forward rubbing action in the direction of the grain using soap and warm water.

Rust spots or 'tea stains' can occur on the surface of the material, these are normally caused by contamination from ordinary mild steel, particularly in areas where construction work has been undertaken. Such stains can be removed using Rust Remover 410.

In cases where the surface is severely stained because of severe environmental conditions or scratched due to misuse, it may still be possible to restore the original finish using chemicals such as Oxalic Acid solution.

There are many stainless steel polishes available to enhance the surface finish. We recommend Mister Stainless Ltd. as a provider for stainless steel **cleaning products**.



Bermondsey Square, London

KENT STAINLESS

“A PARTNER YOU CAN RELY ON”



Contact us

Phone: +353 53 914 3216
UK Freephone: 0800 376 8377
USA: 781 374 7391

Email: info@kentstainless.com
Address: Ardcavan, Wexford, Ireland, Y35 CRW2



www.kentstainless.com
 Made in Ireland