

# Kent Solo Paver

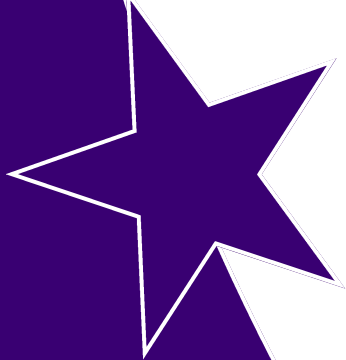



## KENT SOLO PAVER KSP-450/450

Kent Solo Paver Manholes for Block Paved Areas, KSP-450/450, have unique Laser Cut lettering on the lifting corners to indicate services.

The Recessed cover units are manufactured in accordance with EN124 and FACTA standards and are available in various loadings. The covers are 80mm deep as standard (100mm deep is a popular option) and are fabricated in 3mm, 4mm, 6mm or 8mm thick stainless steel as standard, and galvanised versions are available.

The Kent Solo Pavers are one of Kent Stainless most popular products and are commonly found on main streets, national monuments and government buildings. They are available to view in Kings Cross (London) Wexford town (Ireland) and Dublin Airport (Ireland).

### Features:

- Laser cut lettering in four corners
- Triangle lifting points aid block cutting
- Identification normally comprises
  - Manufacturer
  - Loading
  - Year of Manufacture
  - Utility Identification
- Tapered sides to prevent jamming
- Full Perimeter Flange

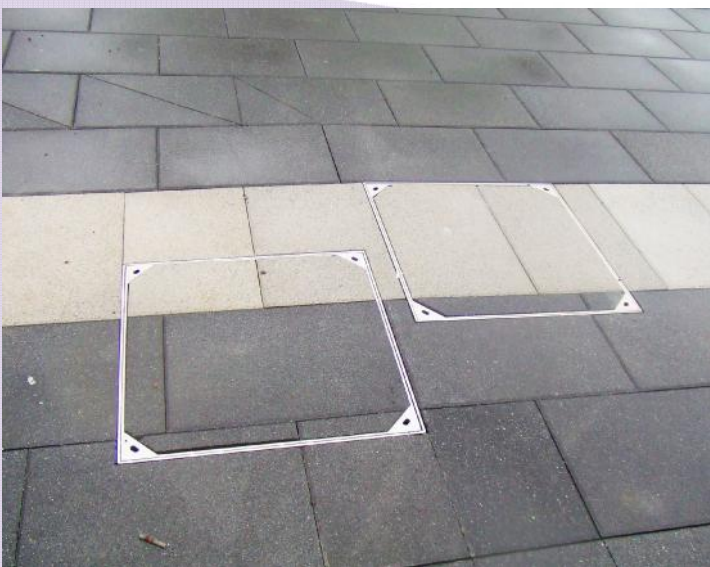

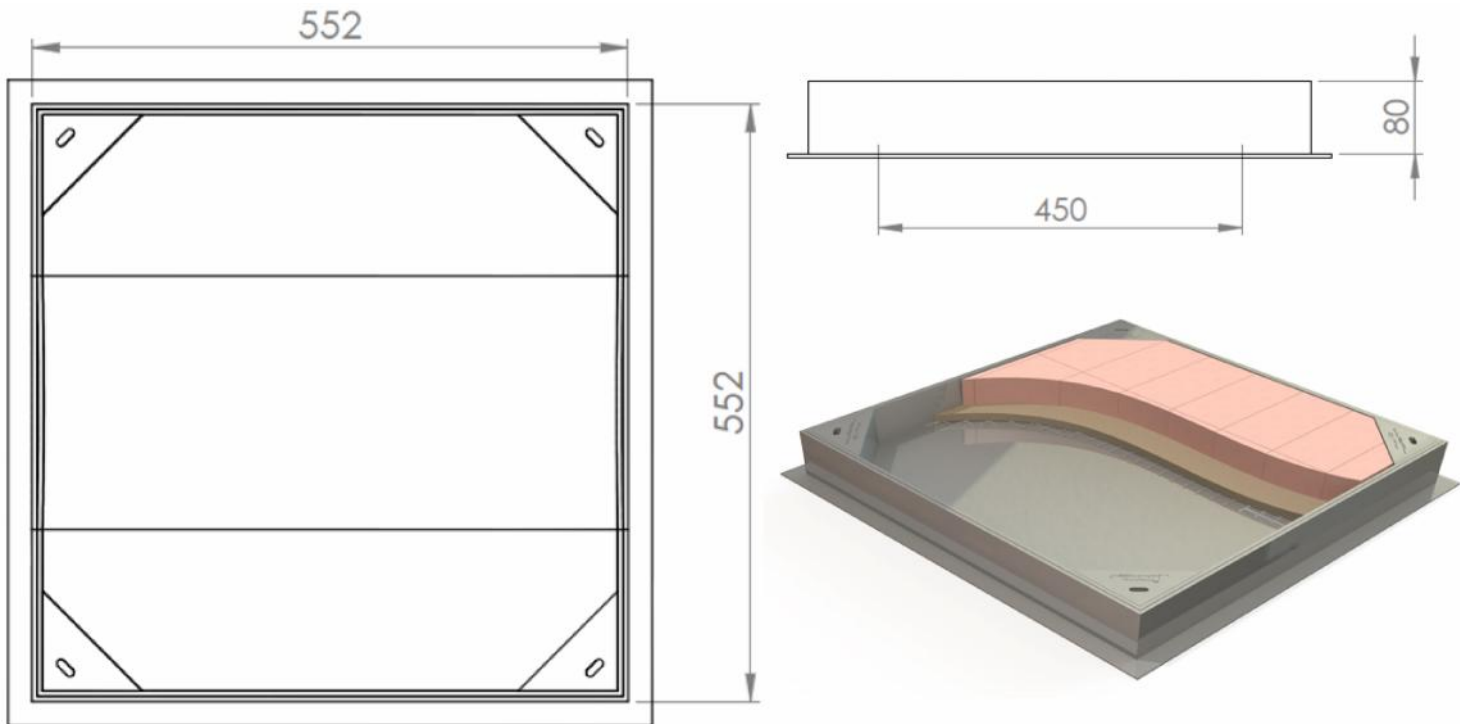
**KENT SOLO PAVER KSP-450/450**

Product Code	Clear Opening	Tray Depth	Visible Frame Size (Unsealed)
KSP-450/450	450mm x 450mm	80mm	552mm x 552mm
KSP600/450	600mm x 450mm	80mm	702mm x 552mm
KSP600/600	600mm x 600mm	80mm	702mm x 702mm
KSP-750/600	750mm x 600mm	80mm	852mm x 702mm
KSP-750/750	750mm x 750mm	80mm	852mm x 852mm
KSP-900/600	900mm x 600mm	80mm	1002mm x 702mm
KSP900/750	900mm x 750mm	80mm	1002mm x 852mm
KSP-900/900	900mm x 900mm	80mm	1002mm x 1002mm

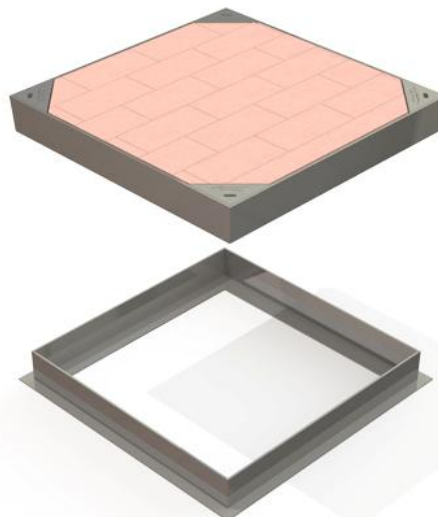

## KENT SOLO PAVER KSP-450/450

### Fixing Details

**Step 1:** When the manhole is being installed, please ensure that the tray is fitted in the frame. This will prevent both the tray and frame from distorting when the concrete is being poured and whilst concrete is setting .

**Step 2:** Once the concrete has set, the tray can then be removed and the grease seal area can be filled. Use Marine grade grease, to a depth of 3mm below the top of the channel recess.

**Step 3:** The depth and condition of the grease should be checked at constant intervals of every two to three months.

**Step 4:** The above details are to ensure that the true benefits of the double sealed manhole are properly achieved throughout the life of the manhole

### Stainless Steel Maintenance

Clean the stainless steel components using warm water with a mild detergent with a non abrasive cloth or sponge. Heavier stains may require the use of a nylon scouring pad or a stainless steel cleaner. To remove paint or graffiti (or light concrete splashes) use a cloth and alkaline or solvent paint strippers according to type of paint. For Satin Finish Stainless try to follow the direction of the grain when cleaning vigorously or polishing. For Bead Blasted Finish use a circular motion. Rust spots or 'tea stains' can occur on the surface of the material, these are normally caused by contamination from ordinary mild steel, particularly in areas where construction work has been undertaken. Where contamination of the stainless has occurred from ordinary mild steel coming into contact with the stainless, use Rust Remover 410. In cases where the surface is severely stained as a result of severe environmental conditions or scratched due to misuse, it may still be possible to restore the original finish using chemicals such as Oxalic Acid solution. There are many stainless steel polishes available to enhance the surface finish. We recommend Mister Stainless Ltd. as a provider for stainless steel cleaning products

### Galvanised Mild Steel Maintenance

Purchase an alkaline cleaner. These products are non-abrasive combinations of detergents and solvents designed to clean and maintain galvanised steel. With the use of rubber gloves, fill a bucket with a gallon of hot (not scalding) water and add one ounce of the Alkaline Cleaner. Stir well. Dip a soft bristle brush into the cleaning solution. Beginning at one end of the Product, scrub gently, using a circular motion. Go from one end of the product to the other, overlapping the circles repeatedly to make sure you do not miss any spots. Rub the towel over the product to make sure the steel has been cleaned. The towel will remove any excess water or cleaner from your project. After you have used the towel, let it dry.

**Specify**

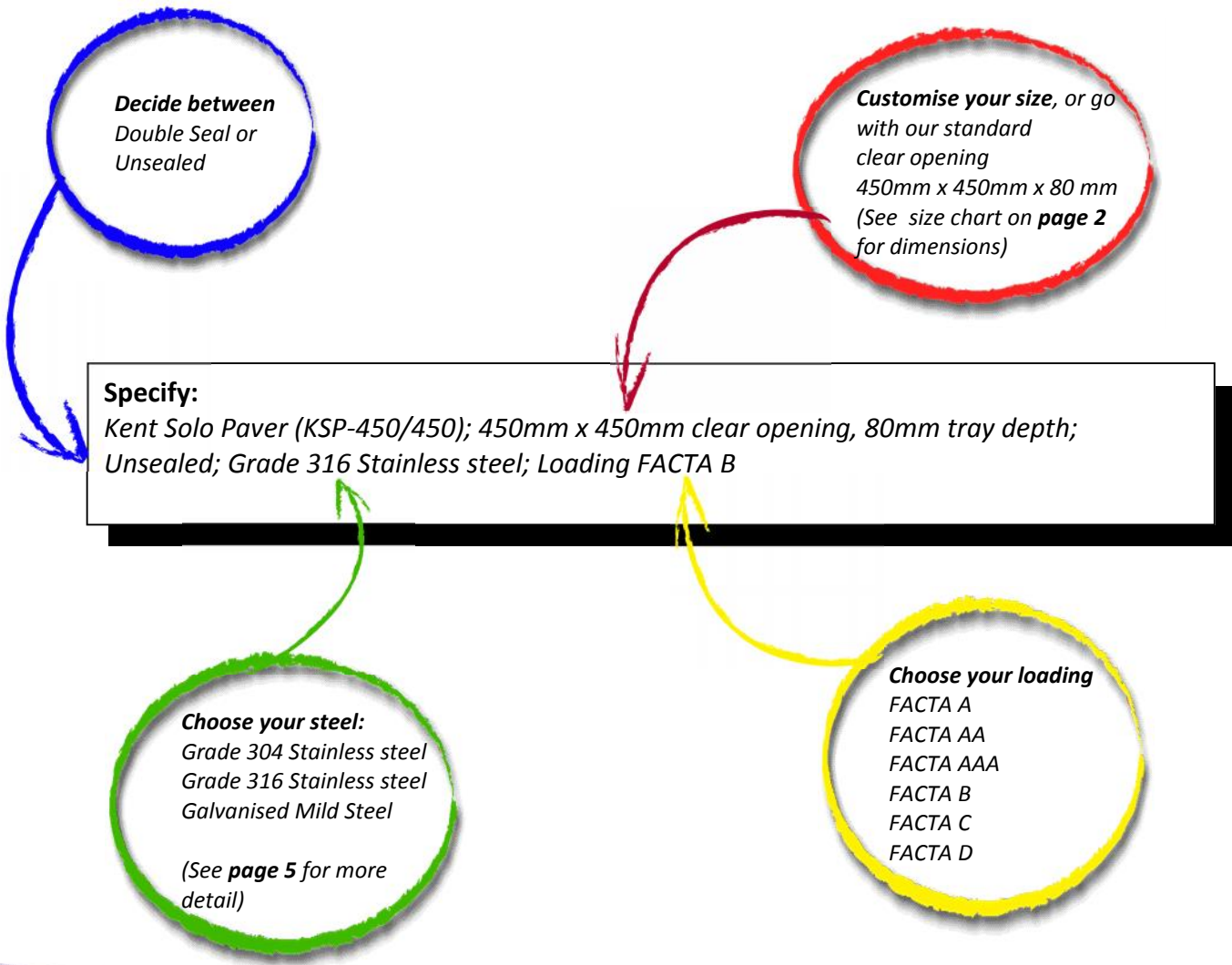

FACTA Class	Slow Moving wheel Loads	Kent Safety Test (Unfilled)
A	0.6T	0.8T
AA	1.5T	3.1T
AAA	2.5T	5.2T
B	5T	10.1T
C	6.5T	13.2T
D	11T	22T

BSEN124	Slow Moving wheel Loads	Kent Safety Test (Unfilled)
A15	0.6T	1.5T
B125	5.0T	12.5T
C250	6.5T	25.0T
D400	11.0T	40.0T

Options
Unsealed or Double Sealed
Grade 304L Stainless Steel
Grade 316L Stainless Steel
Mild Steel Galvanised to BS EN ISO 1461 (1999)
Mild Steel Galvanised to 140 Micron minimum for middle East projects



## KENT SOLO PAVER KSP-450/450

### Grade 304 vs. 316 Stainless Steel

The last thing our we want for our customers is to have to deal with staining or rust on their Kent Stainless Steel products. If your product will be exposed to harsh or coastal environments , we recommend upgrading to grade 316L stainless steel which extends the life span of the product for years more. Consider this fact when planning a future project.

#### Grade 304L Stainless Steel

304 stainless steel is the most common form of stainless steel used around the world. It contains between 16 and 24 percent chromium and up to 35 percent nickel, as well as small amounts of carbon and manganese. 304 can withstand corrosion from most oxidizing acids. That durability makes 304 easy to sanitize, and therefore ideal for kitchen and food applications. It is also common in buildings, décor, and site furnishings. However, it is susceptible to corrosion from chloride solutions, or from saline environments like the coast.

#### **Benefits**

- Lowest Cost Corrosion resistant option
- Resistant to oxidation
- Low maintenance
- Durable and strong

#### Grade 316L Stainless Steel

316 grade is the second-most common form of stainless steel. It has almost the same physical and mechanical properties as 304 stainless steel, and contains a similar material make-up. The key difference is that 316 stainless steel incorporates about 2 to 3 percent molybdenum. The addition increases corrosion resistance, particularly against chlorides and other industrial solvents. 316 stainless steel is commonly used in many industrial applications involving processing chemicals, as well as high-saline environments such as coastal regions and outdoor areas where de-icing salts are common. Due to its non-reactive qualities, 316 stainless steel is also used in the manufacture of medical surgical instruments.

#### **Benefits**

- Superior Corrosion resistance
- Chlorine Resistant
- Low maintenance
- Durable and strong

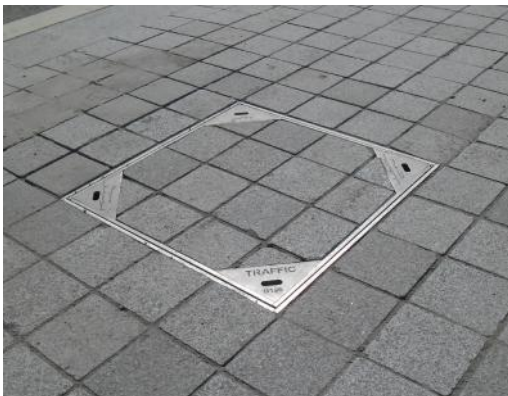

*Grade 316 Stainless Steel Kent Solo Paver  
installed in Lusail, Qatar*



*Grade 304 Stainless Steel Kent Solo Paver  
installed in Hemel Hempstead, London*

**Testimonials**

**PARSONS**  
 Parsons International Limited  
 P. O. Box 2091, Doha, Qatar • Tel: (+974) 4408-8444 • Fax: (974) 4437-7434 • www.parsons.com

Kent Stainless  
 Ankovan, Westford  
 Ireland

5 January 2012

Attention : Mr. Shane Curtis & Michael Harley  
 Project : Lissill Construction Package 1 - CPI  
 Subject : CPI: Kent Stainless, Lissill City, Qatar

Dear Shane & Michael,

I am writing to express my thanks for the works delivered by Kent Stainless to the Lissill Project in Doha. Your willingness to work with the client, designers and contractors to finalise the specifier detailing, produce the shop drawings and samples has been second to none and has added significant value to the project.

The in-house engineering completed by Kent Stainless and the knowledge and advice given to finalise the design was outstanding. All the products delivered to date have been fully compliant and of the highest quality.

Finally, your frequent presence on site and customer focus has enabled this technically difficult package of works to be finalised in the shortest possible time.

We hope to see you again on future projects.

Yours Sincerely

Patrick McComack  
 Parsons CPI

*“ The In-house engineering completed by Kent Stainless and the Knowledge and advice given to finalise the design was outstanding ”*

**- Parsons**

**SKANSKA**

Skanska Construction UK Ltd T/A  
 Skanska Infrastructure Services  
 Ltd  
 Maple Grove House  
 Dunham Way  
 Maple Grove  
 Rixton, Lancashire  
 Warrington, WIG3 9SS

Phone: +44 (0)1923 776888  
 Fax: +44 (0)1923 423593  
 Web: www.skanska.co.uk  
 Reg. in: England  
 Reg. No: 5314329  
 Registered Office: Maple Grove House  
 Dunham Way, Maple Grove, Warrington,  
 Cheshire, Warrington, WIG3 9SS

For the attention of: Michael Hurley

Kent Stainless  
 Ardavin  
 Westford  
 Ireland

Our ref: MW/002/20312 29 March 2010  
 Your ref:

Dear Michael,

Re: Letchworth Garden City, Manholes, Grits, Drainage & Tree Pit Frames

With reference to Letchworth Garden City, we were delighted to work on such a prestigious award winning scheme. The choice of subcontractor and suppliers was crucial to us delivering such a high standard & Kent Stainless were instrumental in this.

As with all our projects during the last 5 years Kent delivered promptly and with the right quality - thanks for your help & keep up the good work.

The client and the main contractor both were delighted with the quality of the work supplied by Kent Stainless. You showed great flexibility and your quality was right first time again.

Yours faithfully,  
 for and on behalf of  
 Skanska Infrastructure Services

Matt Wincott

*“ The client and the main contractor both were delighted with the quality of the work supplied by Kent Stainless ”*

**- Skanska**

**DIRECTOR OF SERVICES  
 CORPORATE AFFAIRS & ROADS  
 AODCW**

15<sup>th</sup> January 2010

Mr. Stephen Roche,  
 Kent Stainless,  
 Ankovan,  
 Westford,  
 Ireland.

RE: **Wexford Main Street Regeneration**

Dear Stephen,

Thanks for your help with the designs of manholes and gully covers for Wexford Main Street. We invested heavily in the new paving works and to break up the beautiful stone work with solid cast covers would have been a real shame. The solutions you provided with recessed covers in stainless steel with laser engraving blended in perfectly with the look and feel we wanted to portray for the street.

Because of the engineering know-how you provided and flexibility in design, we will certainly return to Kents for further work. We were designed to find an Irish manufacturer could provide all solutions, and even better a Wexford based engineering firm.

Yours faithfully,

  
 Adrian Doyle,  
 Director of Services,  
 Corporate Affairs & Roads

e-mail: adrian.doyle@wexfordcc.ie  
 tel: 053 9176400

100 Years of Community Service  
 Cuid 100 bli ag teilim ar bhun-ádh na hÉireann

*“ Because of the engineering know-how you provided and flexibility in design, we will certainly return to Kents for further work ”*

**- Wexford County Council**



**Kent Stainless Ltd**

Ardcavan, Wexford, Ireland

**TEL NO:** +353 53 9143216  
**UK FREEPHONE:** 0800 376 8377  
**FAX:** +353 53 9141802  
**WEB:** [www.kentstainless.com](http://www.kentstainless.com)  
**EMAIL:** [info@kentstainless.com](mailto:info@kentstainless.com)

