



Dubline Wayfinding Monolith



Specify:

Kent Dublin Wayfinding Monolith KDWFM2600; Grade 316L Stainless Steel; 10mm.Toughened Glass Panels; Reverse Mounted Posters; Bright Peened Finish.

The Kent Dublin Wayfinding Monolith was designed and manufactured for the “Dubline” Project in Dublin City Centre. It has a very simple and modern design that makes it ideal for all public areas, its large screen makes viewing easy for pedestrians. The logos are Shot Peened through a mask/ template giving the utmost durability.



Features:

- Grade 316L Stainless Steel
- 10mm toughened glass panels
- Bright peened finish
- Reverse mounted posters
- Laser cut logos

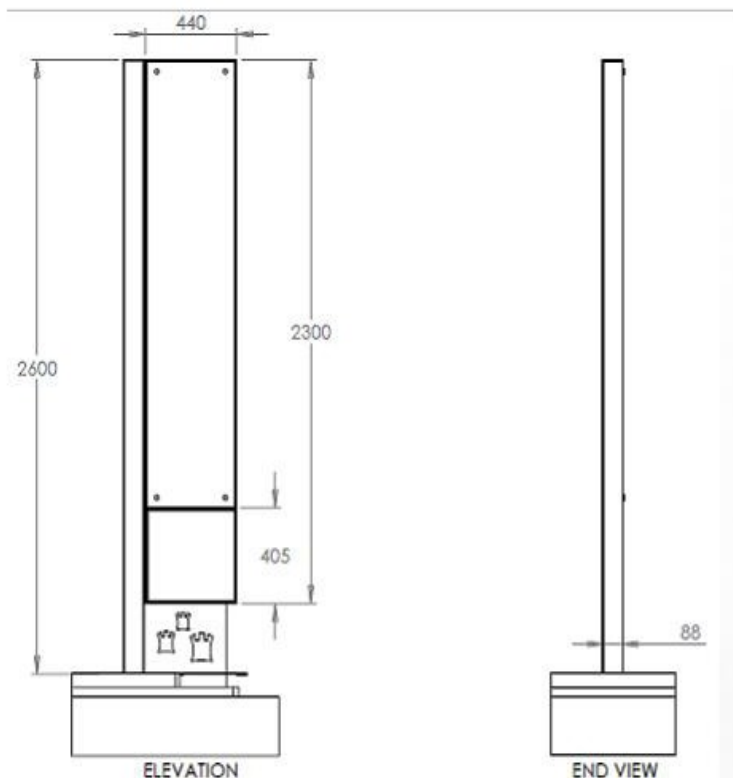

Kent Dubline Wayfinding Monolith KDWFM2600



Reference	Height	width
Kent Dubline Wayfinding Monolith KDWFM2600	2600mm	4400mm



CONCEPT RENDERING

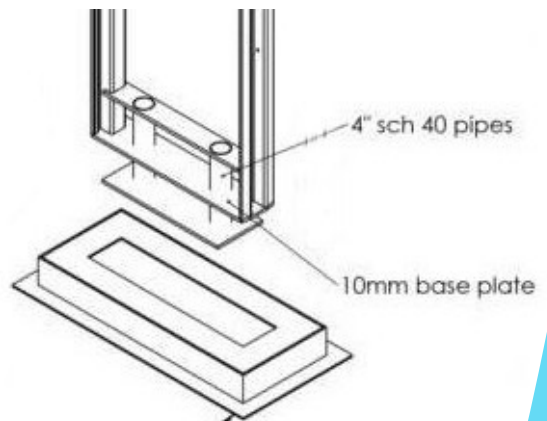

STAINLESS STEEL ACCESS COVER AND FRAME
FOR MOUNTING ON SLOPING GROUND

