

# ELDERWOOD SIGN



# Kent Square Post Elderwood Sign KSPES1250/350

## Specify:

Kent Square Post Elderwood Sign KSPES1250/350; 1250mm Long; Single sided; Grade 316L Stainless Steel; 350mm Panel Height; 1 Line of Text; Bright Satin Finish; Visible Flange

The Kent Square Post Elderwood Sign KSPES1250/350 offers a sturdy high quality solution to the installation of commercial signage. This single sided sign comes complete with laser cut lettering. Fully enclosed at the back with all ends blanked off. Main signs manufactured from 3mm thick stainless steel. As standard, signs are 1200mm high from ground level, with 100mm Box Section posts. A double sided option is available.

## Features

- Grade 316L Stainless Steel construction
- Laser cut lettering
- Bright Satin Finish
- 3mm thick, vandal resistant sign panels
- Vandal resistant lettering, Laser cut with vinyl backing to any colour

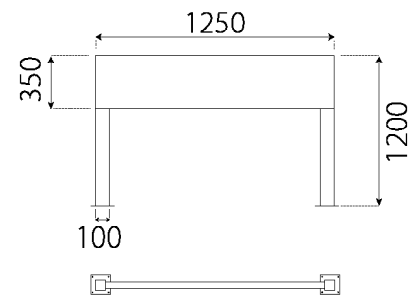



Kent Square Post  
Elderwood Sign KSPES1250/350

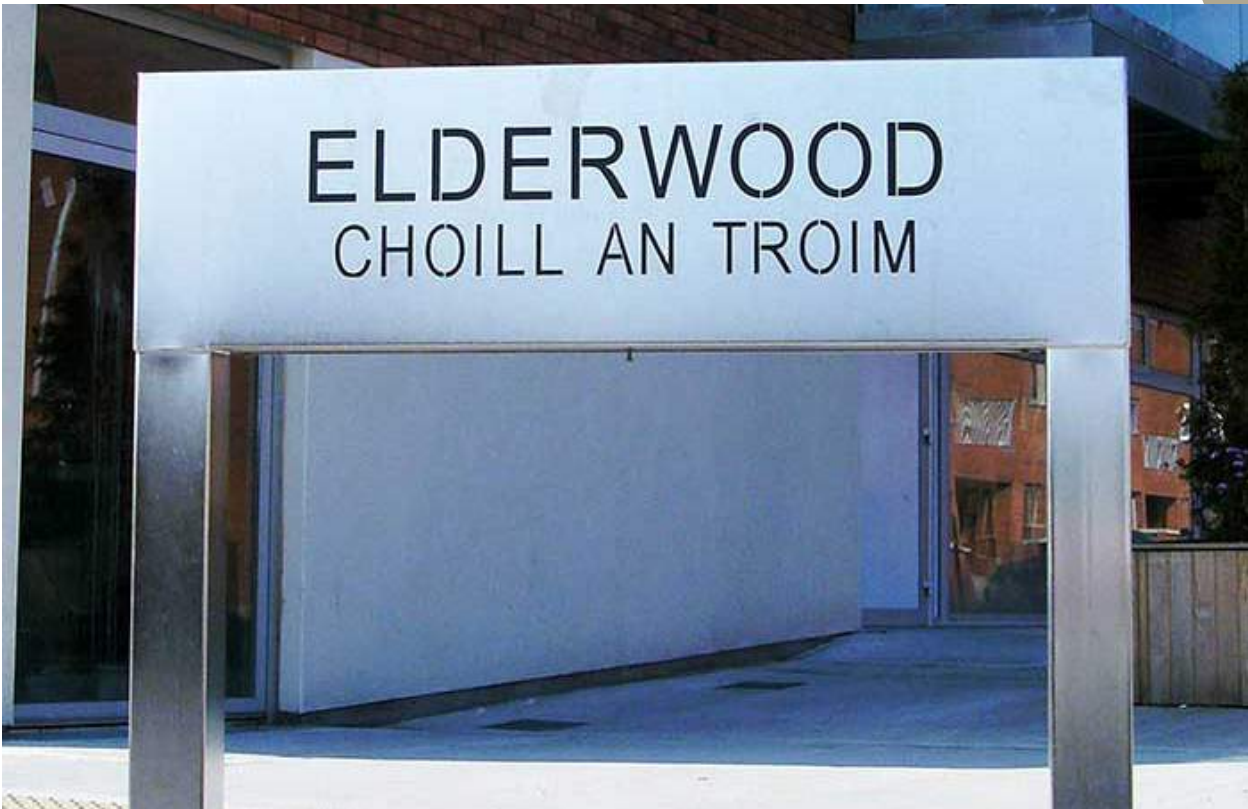

Product Dimentions:

Reference	Height	Width	Panel Height	Lines of text
Kent Square Post Elderwood Sign KSPES1250/350	1200mm	1250mm	350mm	1
Kent Square Post Elderwood Sign KSPES1500/515	1200mm	1500mm	515mm	2
Kent Square Post Elderwood Sign KSPES1500/350	1200mm	1500mm	730mm	3

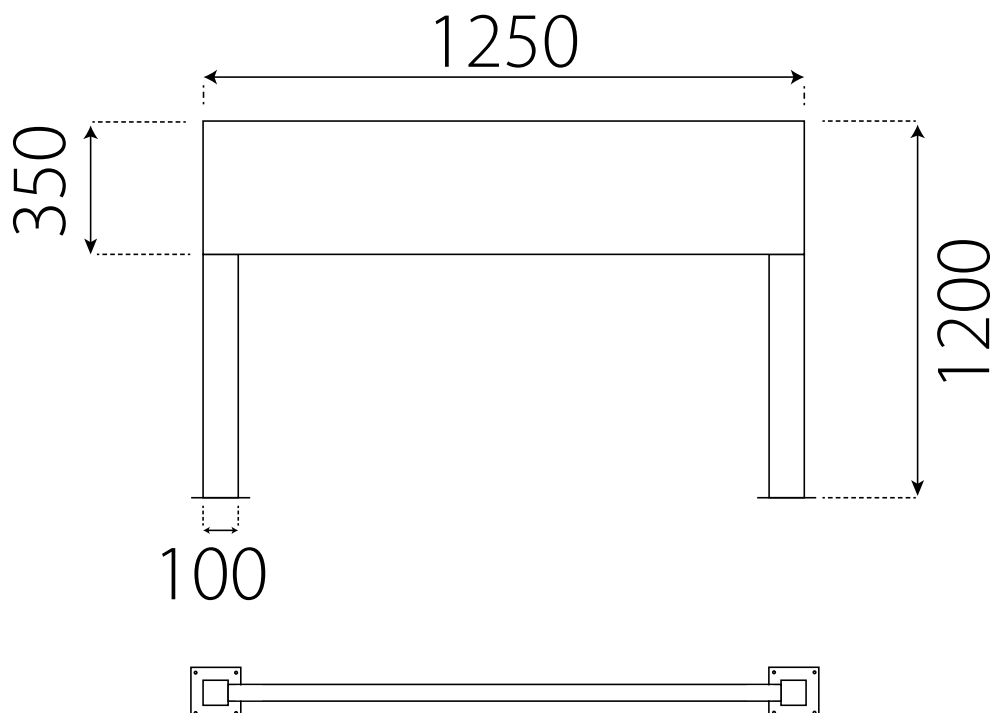

# Kent Square Post Elderwood Sign KSPES1250/350

## Visible Flange:

- Ensure that the surface to which the stand is mounted is sufficiently strong.
- Position the pole in the correct location. Mark the holes and drill into the surface.
- Place the pole directly over the holes and then fix the pole to the surface using M12 bolts.

## Buried Flange:

- Cast a foundation with a minimum dimension of L600 x W600 x D600mm below the surface.
- Once concrete is set follow steps 1-3 as per flange detail above.
- Fill hole with grout and replace slabs to finish of the pole

## Cast In:

- Remove pavement and excavate a hole to minimum dimensions of L600 x W600 x D600mm.
- Position your pole in the correct position ensuring correct height and then prop the stand securely.
- Fill the hole with concrete up to the level of the underside of the pavement ensuring a good smooth surface finish.
- Remove props, replace the paving slabs, and ensure that they are well bedded in.

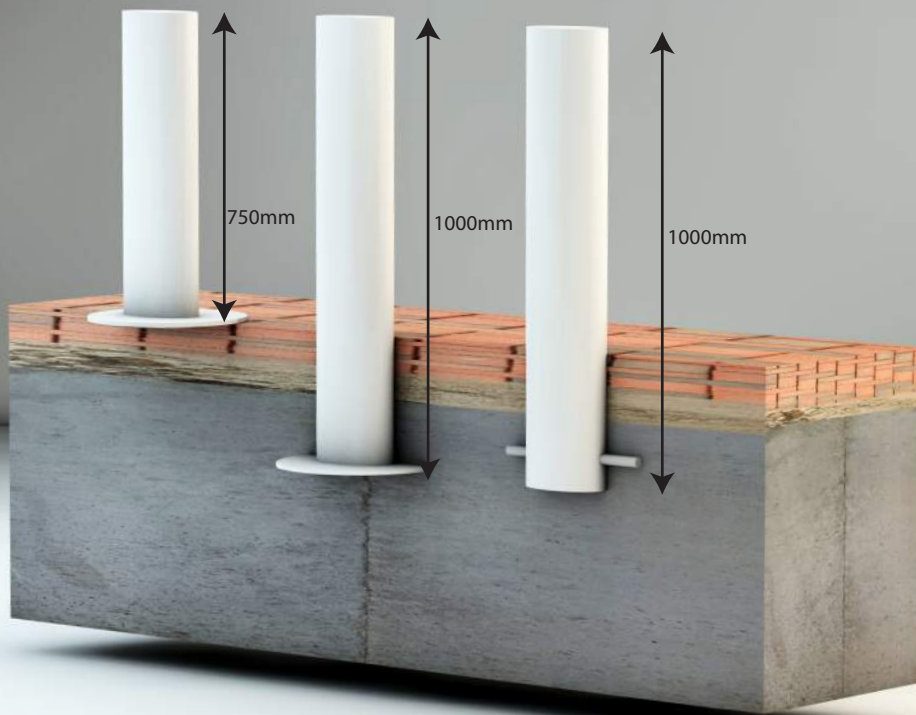

# Kent Square Post Elderwood Sign KSPES1250/350

Product Options:

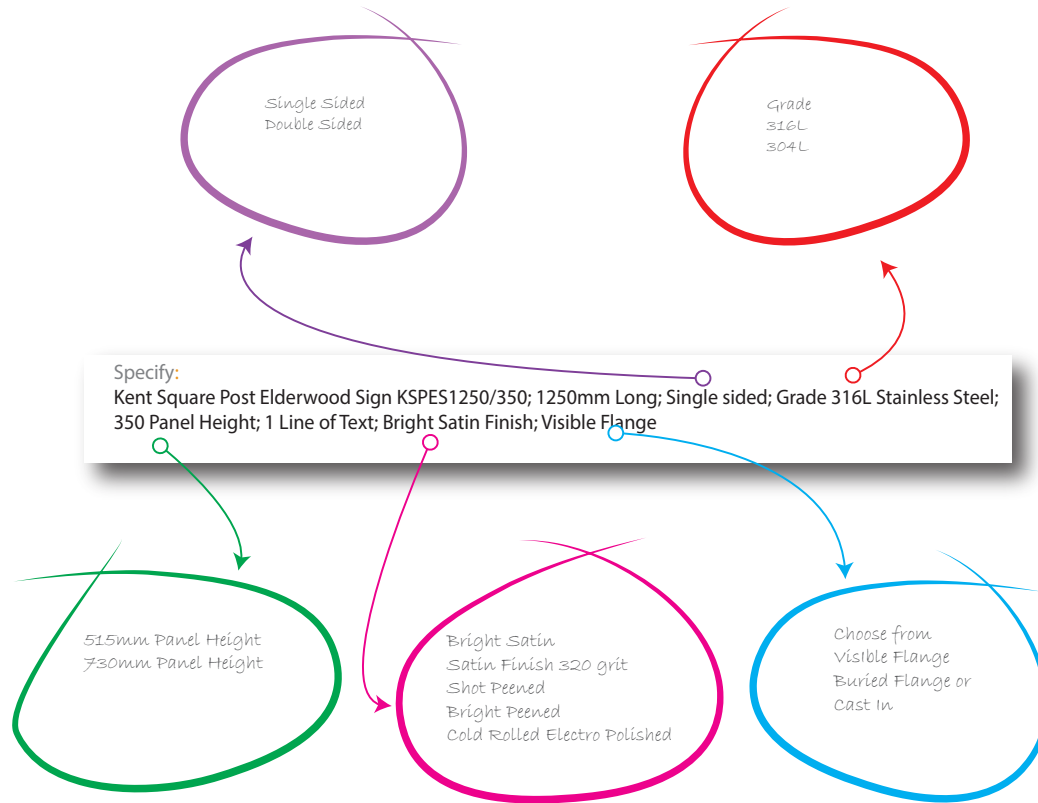

# Kent Square Post Elderwood Sign KSPE1250/350

## Overview

The Kent Square Post Elderwood Sign KSPE1250/350 offers a sturdy high quality solution to the installation of commercial signage. This single sided sign comes complete with laser cut lettering. Fully enclosed at the back with all ends blanked off. Manufactured from 3mm thick stainless steel.

## Maintenance

Stainless Steel:

Clean the stainless steel components using warm water with a mild detergent with a non-abrasive cloth or sponge. Heavier stains may require the use of a nylon-scouring pad or a stainless steel cleaner. To remove paint or graffiti use a cloth and Alkaline or solvent paint strippers according to type of paint. In the case of a bead blasted finish, where abrasive cleaning is required, always use a random circular rubbing action with a cloth. In the case of brushed finishes the surface consists of uniform fine 'scratches' running in one direction so where abrasive cleaning is required always use a straight back and forward rubbing action in the direction of the grain using soap and warm water. Rust spots or 'tea stains' can occur on the surface of the material, these are normally caused by contamination from ordinary mild steel, particularly in areas where construction work has been undertaken. Such stains can be removed using Rust Remover 410. In cases where the surface is severely stained because of severe environmental conditions or scratched due to misuse, it may still be possible to restore the original finish using chemicals such as Oxalic Acid solution. There are many stainless steel polishes available to enhance the surface finish. We recommend Mister Stainless Ltd. as a provider for stainless steel cleaning products.



# ELDERWOOD

CHOILL AN TROIM

