



Kent
STAINLESS



Kent
STAINLESS

KSBC300 Industrial Box Channel

The KSBC300 channel is used in very high flow applications.

It is extensively used in Food, Dairy, Beverage and Pharmaceutical factories and is customisable in a huge variety of features - In grade 304 stainless as standard, often used in grade 316 and size can be customised to suit any projects.

Watertight connections are made with either flange & gasket joints, or preparation for site welding.

The Flow Rates shown below are examples for typical applications, however we can achieve much higher flow rates in customized variations of this channel.

Features:

- 300mm wide body as standard with 25mm turnout and turndown each side
- 350mm outside edge to outside edge
- Used with either trapped 219mm or 273mm Gully outlet
- 125-150mm start depth
- 1:150 (0.06%) pre-sloped fall built in.

Applications/Industries

- ◇ Industrial
- ◇ Food
- ◇ Dairy
- ◇ Beverage
- ◇ Pharmaceutical



OPTIONAL



GRATING OPTIONS

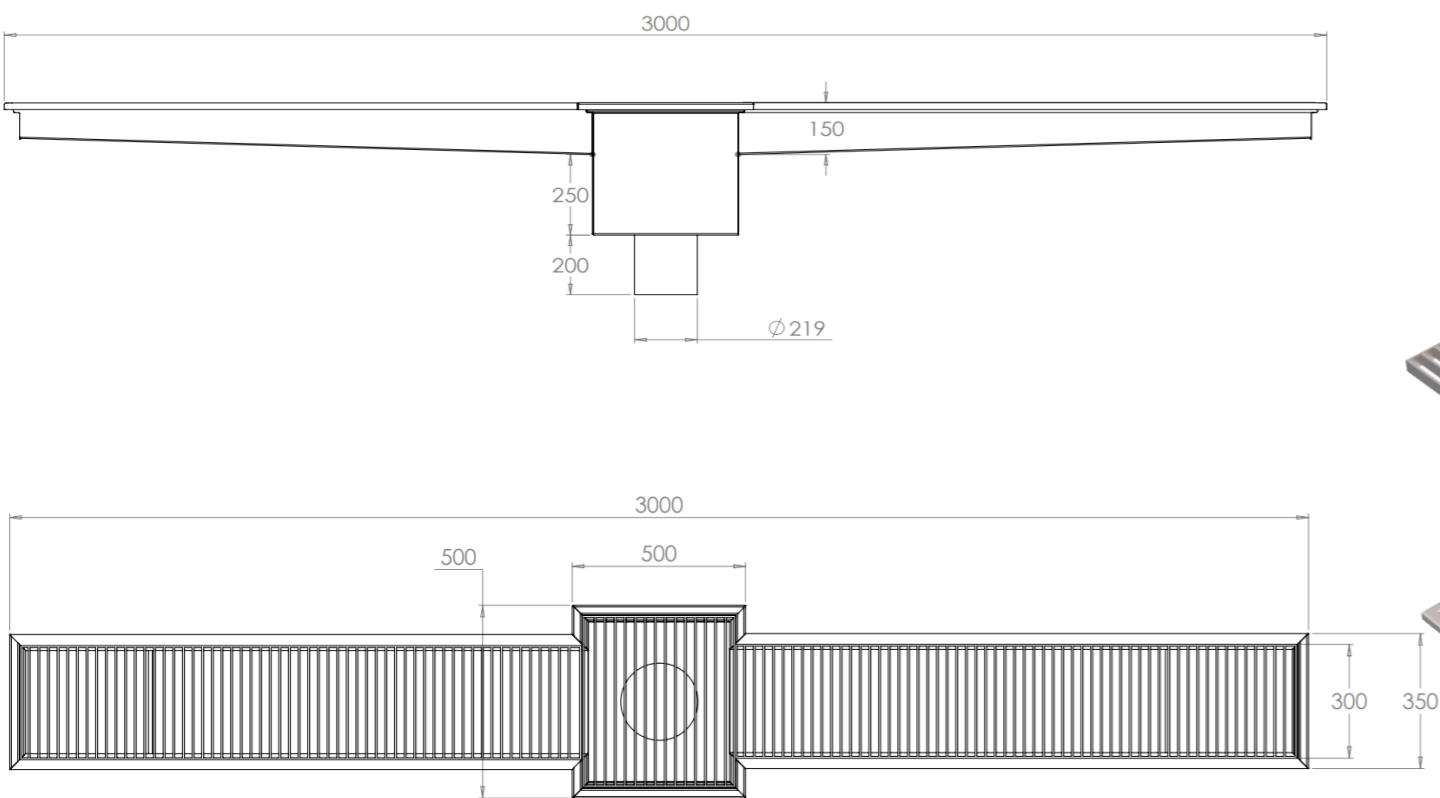
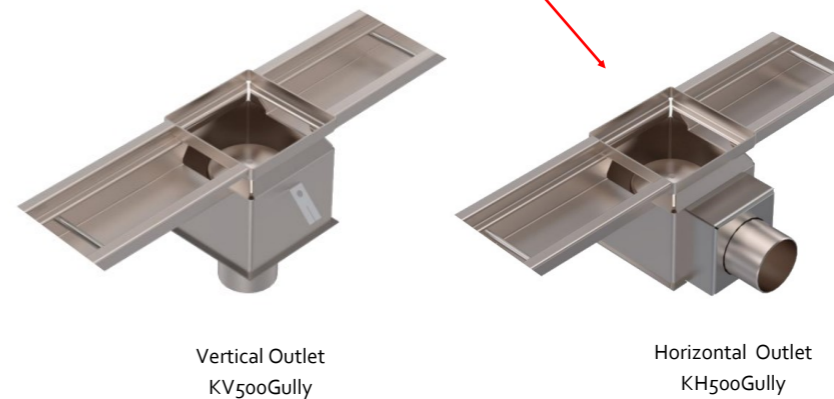
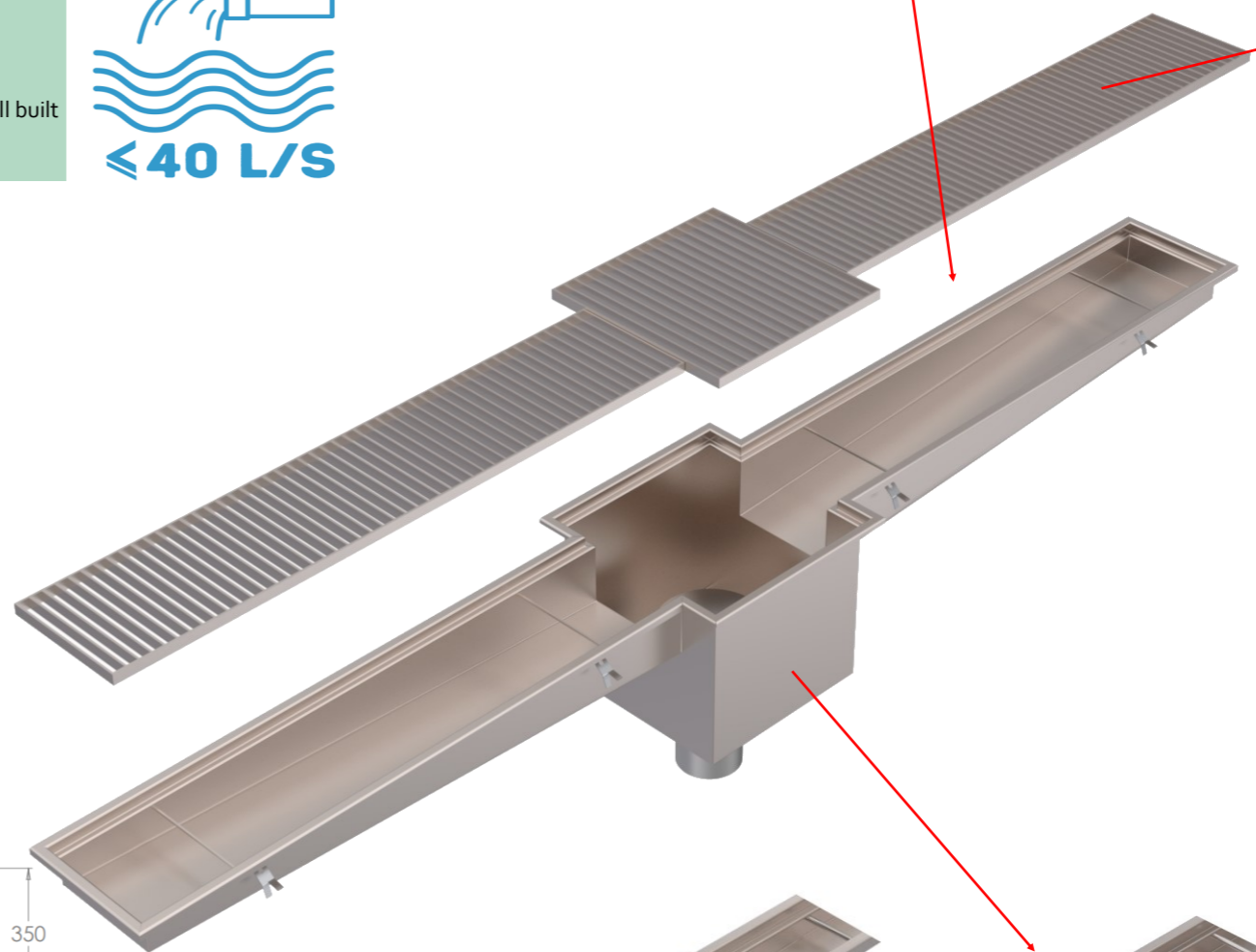
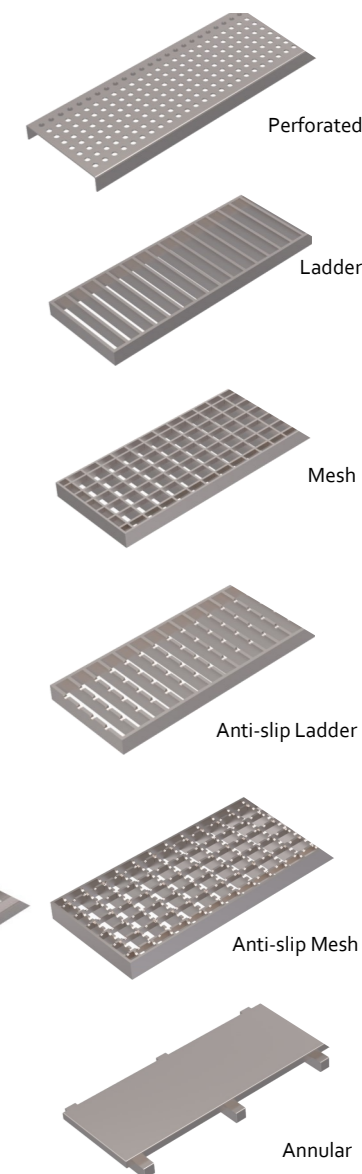

Product Code	Min. start depth	Width	Outer Width	Outlet	Flow Rate
KSBC300/KV500/219	125	300	350	219	32 l/s
KSBC300/KH500/219	125	300	350	219	19 l/s
KSBC300/KV500/273	150	300	350	273	40 l/s
KSBC300/KH500/273	150	300	350	273	23 l/s

Specify: Kent Standard Box Channel KSBC300/KV500; to take 3000mm wide grating; Grade 304 Stainless Steel; Grating will be Kent Anti-Slip Ladder Grating Type; Load M125.

(amend underlined words to suit project)

BS EN1433 Loading Class L15 / R50 / M125 / N250 / P400

Our internal channels can be subjected to very heavy loads but must have the correct heavy duty grating to achieve these loads. Suitable for Factories and Leisure Centres.