

## KNEC 150 Internal Neat Edge Channel

The KNEC150 (INT) is a stainless steel channel with rigid discreet neat edge shoulders that is suitable for internal installation.

As standard, this channel comes with a 150mm clear opening. However, can also be customised to suit project requirements.

This channel can be supplied with various gratings including heel safe and barefoot for leisure centres, right up to very heavy duty for factories.

The channel is easily fixed together on site by bolting the flanges together. Loadings can vary from pedestrian to heavy traffic vehicle traffic depending on the choice of grating and profile of concrete surrounding the channel.

When used internally this channel is supplied with a water tight flange and gasket connection. (See Fig 1).

When used internally this channel has a bell type foul odour trap as standard. (See Fig 2).

A similar channel is used externally for urban landscape projects with a different connection detail and without a foul air trap. (See KNEC125 EXT)

### Features:

- Pedestrian & vehicle loadings available.
- 304L Stainless steel as standard
- 150mm clear open as standard
- 50mm start depth as standard
- Site specific lengths available
- Straight or curved option available

### Applications/Industries

- ◇ Industrial
- ◇ Food
- ◇ Dairy
- ◇ Beverage
- ◇ Meat
- ◇ Pharmaceutical
- ◇ Leisure Centres

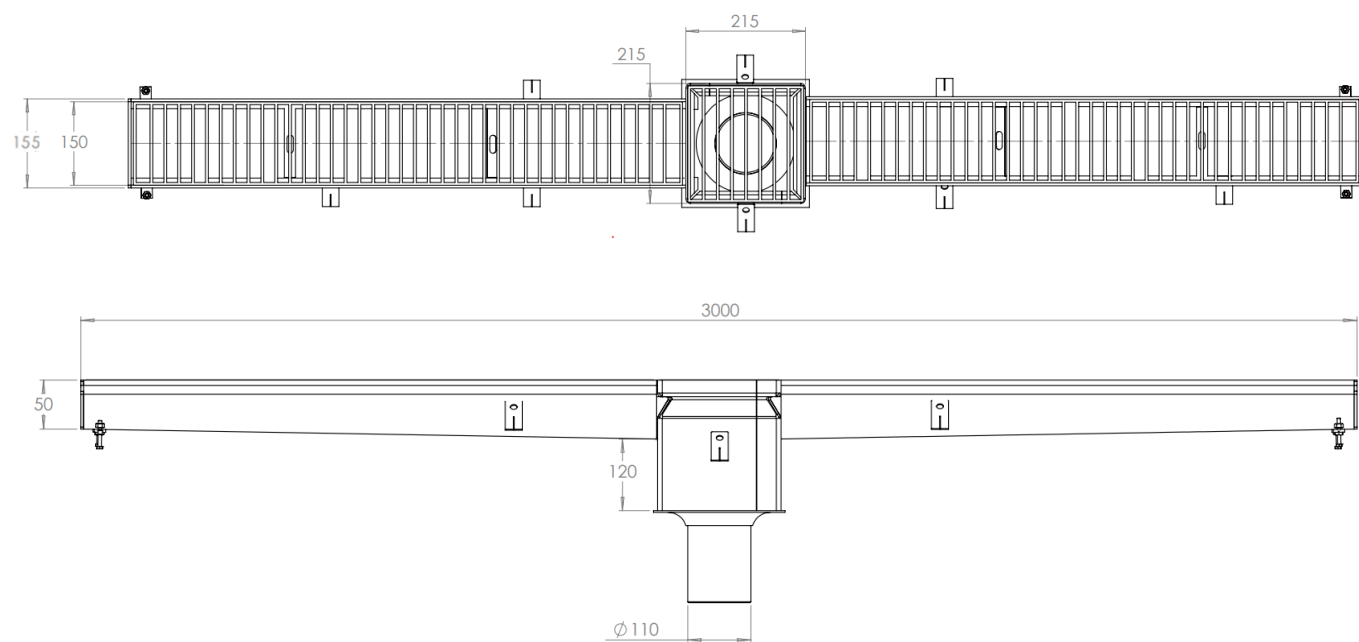

Product Code	Min. start depth	Width	Outer Width	Outlet	Flow Rate
KNEC150/KV215/110 (INT)	50	150	155	110	3.94 l/s
KNEC150/KH215/110 (INT)	50	150	155	110	4.42 l/s
KNEC150/KV315/110 (INT)	50	150	155	160	10.20 l/s
KNEC150/KH315/110 (INT)	50	150	155	160	7.1 l/s

Specify: Kent Neat Edge Channel KNEC150/KV215/110 (INT); to take 150mm wide grating; Grade 304 Stainless Steel; Grating will be Kent Anti-Slip Ladder Grating Type; Load Class B



Water tight flange and gasket connection as standard on all internal projects.

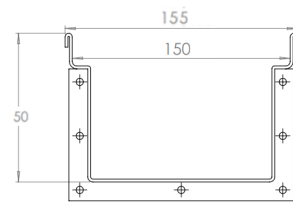

Fig. 1

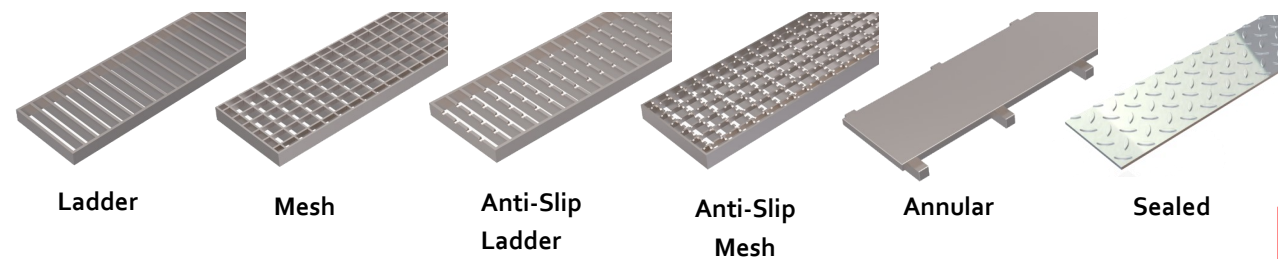

Fig. 2

Integral Foul Air Trap as standard on all internal projects.

## GRATING OPTIONS

### FACTORIES



### LEISURE CENTRES

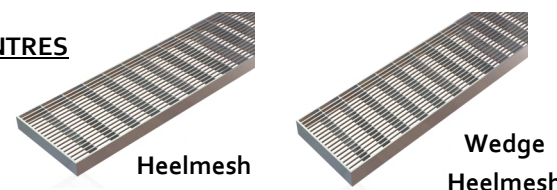

### FACTORIES & LEISURE CENTRES

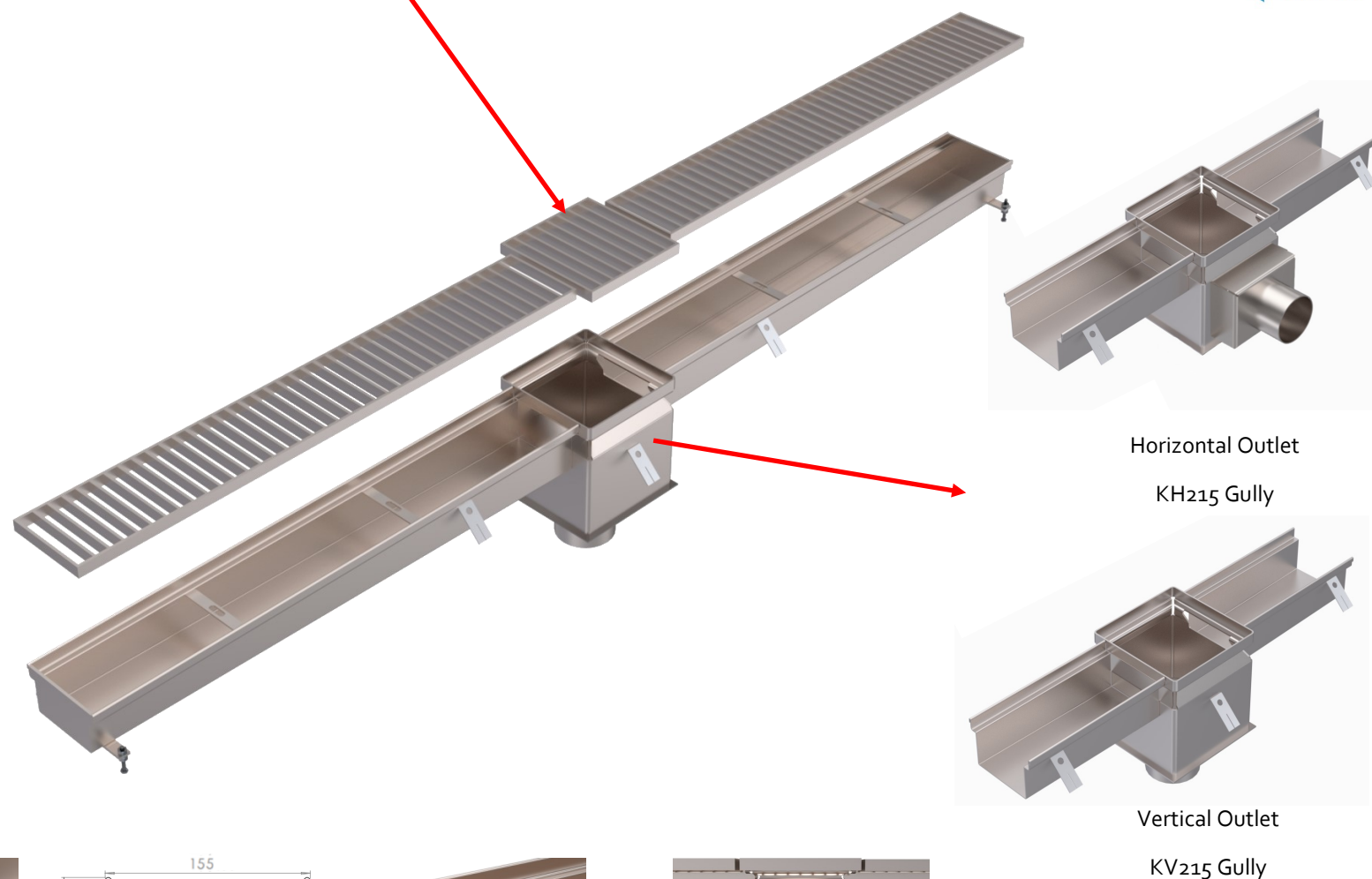
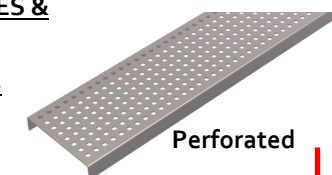

Horizontal Outlet  
KH215 Gully

Vertical Outlet  
KV215 Gully

BS EN1433 Loading Class A15 / B125 / C250 / D400

Our internal channels can be subjected to very heavy loads but must have the correct heavy duty grating to achieve these loads. Suitable for Factories and Leisure Centres.