



SURFACE PROTECTION



KENT STAINLESS
A PARTNER YOU CAN RELY ON



TAKE A VIDEO TOUR OF
OUR FACTORY HERE



for more information on all our products, visit

kentstainless.com

Table of Contents

Introduction	4
Tubular Bump Rails	
Factory Bump Rails.....	5
Airport Bump Rails.....	9
Cleanroom Wall Mounted Bump Rails.....	15
Wall Guards & Crash Rails	
Cleanroom Wall Guards.....	19
Cleanroom Corner Guards.....	23
Cleanroom Crash Rails.....	27
Internal Cleanroom Bollards	31
Internal Factory Bollards	34

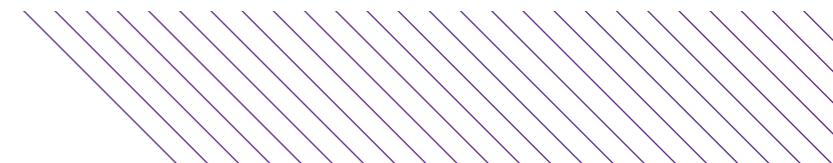



This brochure concentrates on **Surface Protection**.

These products developed as a follow-on to our primary business: Stainless Steel Drainage for the pharmaceutical sector. Once the stainless steel drains have been installed, we work on Surface Protection for the cleanroom and corridor areas.

While this remains our core market, we have expanded to offer these products to hospitals, airports, railway stations, factories, hotels, and a variety of other sectors.

Since 1982 Kent Stainless have been manufacturing engineered products customised to suit projects designed by architects and consulting engineers. Starting out in Wexford, Ireland, we export worldwide and have a manufacturing base in the USA, located in Maryland (MD).

Our focus is to work with architects and consultant engineers at early design stage and develop solutions on a project-by-project basis.



Factory Bump Rail



Airport Bump Rail



Cleanroom Wall Mounted Bump Rail



Cleanroom Wall Guard

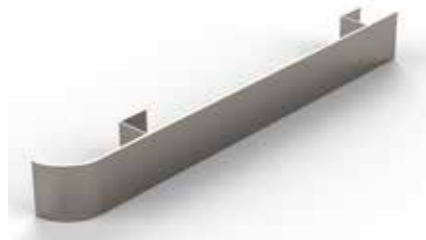

Cleanroom Crash Rail



Cleanroom Corner Guard



Internal Cleanroom Bollard



Internal Factory Bollard



FACTORY BUMP RAILS





Factory Bump Rail

Kent Stainless Factory Bump Rails are a perfect alternative to, or complement for, our Internal Bollards and Corner Guards. The Factory Tubular Bump Rail system has tubular leg supports and usually ends with a turn down to the floor. The intermediate leg is narrower to allow a cleaner weld.

Hidden Fixings are used as standard and this version is designed for Cleanroom or Laboratory projects in the Life Sciences sector. Alternatively, base plates can be used - typically surface mounted and can be accompanied by a cowl. This version is more commonly used for strength and where the rails will receive more frequent impact. A version can also be supplied with longer legs where the contractor core drills a hole and casts in the tube.

Small to Medium sized projects in the USA & Canada will ship from East Coast USA. Major international projects will ship from Ireland.

American projects are mostly made in the USA and made to imperial measures - typically a 2" dia tube and 11" high. This same bump rail supplied to European projects would be supplied as a metric measure 48.3mm dia and 280mm high - rather than an exact conversion of 2" to 50.8mm and 11" to 279.4mm. Approval drawings for each project will be supplied in imperial or in metric as requested and can be customised.

- FEATURES**
- 12GA (2.5mm) thick steel
 - ASTM No. 6 Satin Finish (USA)
 - EN10088 320 Grit Satin Finish (EU)
 - Hidden Fixings as standard for cleanrooms
 - Core Drill & Cast in version available
 - Visible Baseplate with Dome Nuts version available
 - Grade 304L Stainless Steel as standard
 - 316L as an option

- INDUSTRIES**
- Laboratories
 - Pharmaceutical
 - Hospitals
 - Medical Facilities
 - Biomedical

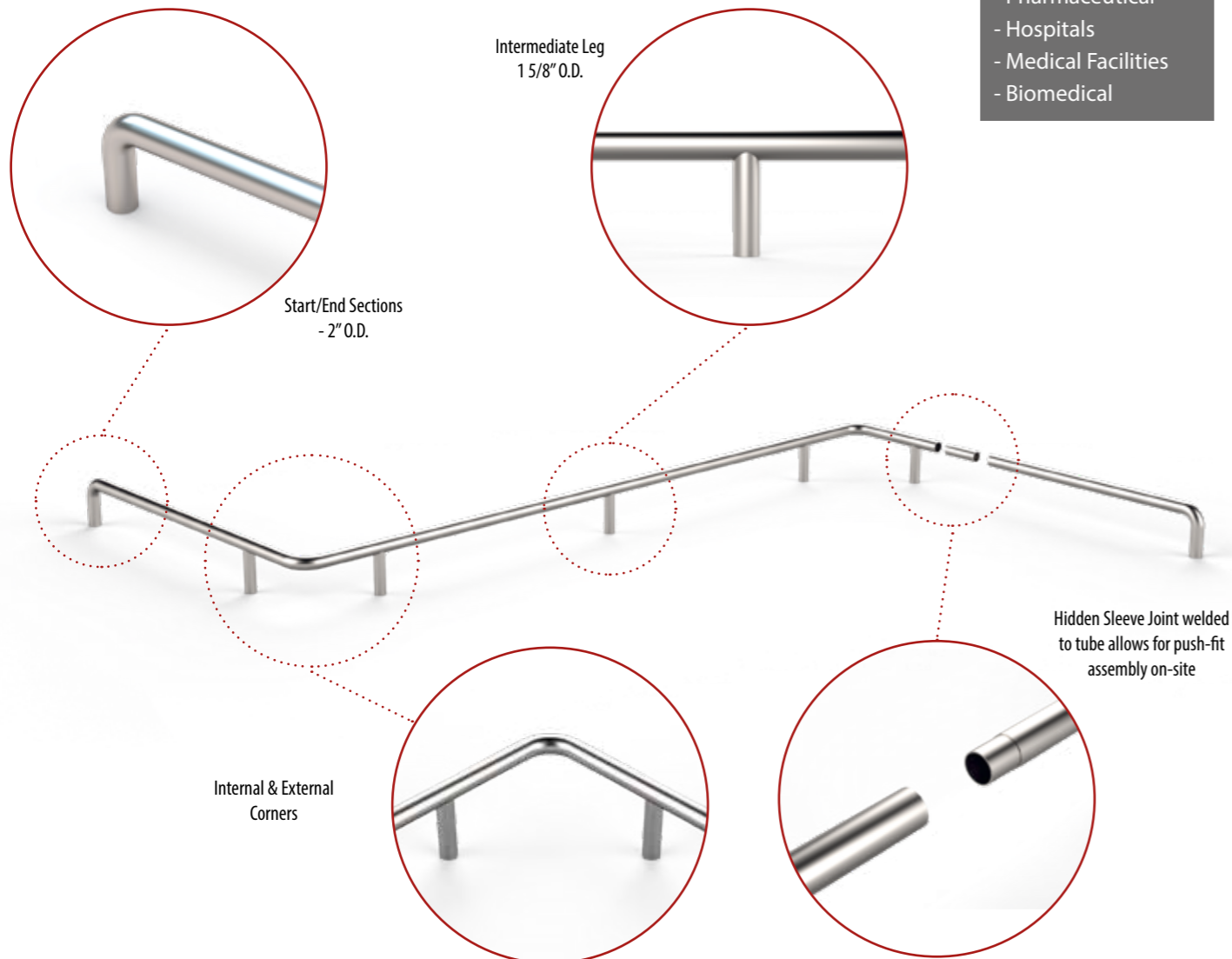

Product Code	Length	Height	Diameter	
			USA	EU
Kent Factory Bump Rail KFBR-50	39.37" (1000mm)	11" (280mm)	2"	48.3mm
Kent Factory Bump Rail KFBR-50	86.61" (2200mm)	11" (280mm)	2"	48.3mm
Kent Factory Bump Rail KFBR-50	117.72" (2990mm)	11" (280mm)	2"	48.3mm

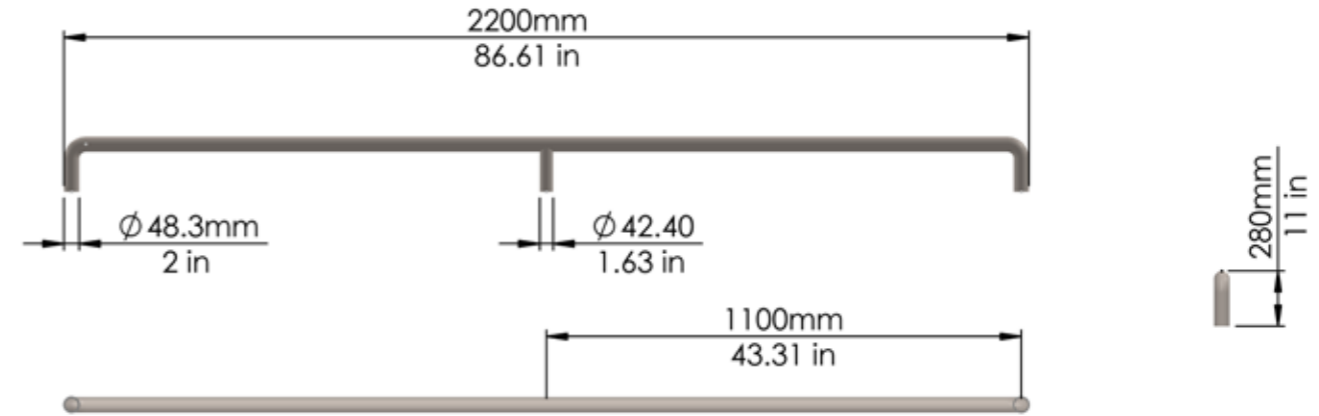

Optimal shipping length is 86.61" or 7.2' - custom lengths are regularly provided

FIXING OPTIONS





SPECIFY

Kent Factory Bump Rail (KFBR-50): ▶ Grade 304L Stainless Steel; ▶ ASTM No. 6 Polish (EN10088 320 Grit Satin Finish); ▶ L: 86.61" (2200mm), H: 11" (280mm), Dia: 2" (48.3mm); ▶ 12GA (2.5mm Thick Steel); ▶ Hidden Fixings.

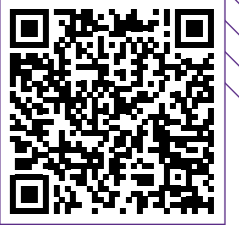

AIRPORT BUMP RAILS





Airport Bump Rail

Kent Stainless Airport Bump Rails are usually chosen for the sleek architectural appearance of the flat bar upright supports. Flat Bar supports are 1/3" or 8mm – but increased in thickness on request for higher loadings.

It can be used also as a Cane Detection Rail for the visually impaired.

This style of Tubular Bump Rail is typically supplied mounted on a circular base plate with countersunk fixings. The base plates are surface mounted as standard or bolted to the subsurface below the tiled floor as an option.

Small to Medium sized projects in the USA & Canada will ship from East Coast USA. Major international projects will ship from Ireland.

American projects are mostly made in the USA and made to imperial measures – typically a 2" dia tube and 11" high. This same bump rail supplied to European projects would be supplied as a metric measure 48.3mm dia and 280mm high – rather than an exact conversion of 2" to 50.8mm and 11" to 279.4mm. Approval drawings for each project will be supplied in imperial or in metric as requested and can be customised.

FEATURES

- 12GA (2.5mm) thick steel
- 0GA (0.3in/8mm) thick supports
- ASTM No. 6 Satin Finish (USA)
- EN10088 320 Grit Satin Finish (EU)
- Circular Baseplates as standard for airports, rail stations etc
- Base plate can be secured above or beneath floor tile
- Grade 304L Stainless Steel as standard
- 316L as an option

INDUSTRIES

- Airports
- Railway Stations
- Stadia
- Bus Terminals

Flush Weld End Cap Straight or turned in 2" O.D.

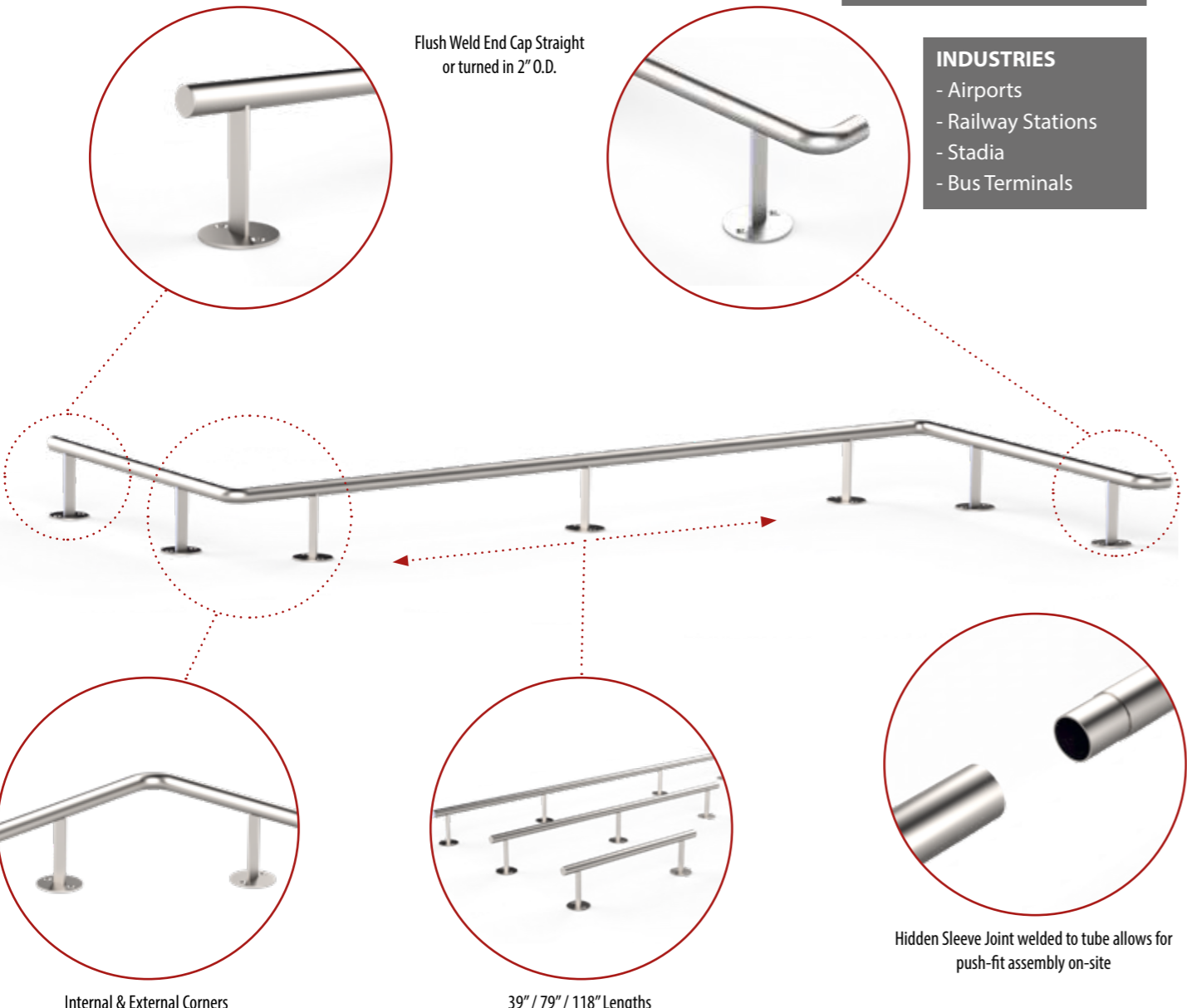

Hidden Sleeve Joint welded to tube allows for push-fit assembly on-site

Internal & External Corners

39" / 79" / 118" Lengths



Product Code	Length	Height	Diameter	
			USA	EU
Kent Airport Bump Rail KABR-50	39.37" (1000mm)	11" (280mm)	2"	48.3mm
Kent Airport Bump Rail KABR-50	78.74" (2000mm)	11" (280mm)	2"	48.3mm
Kent Airport Bump Rail KABR-50	117.72" (2990mm)	11" (280mm)	2"	48.3mm

DRAWINGS

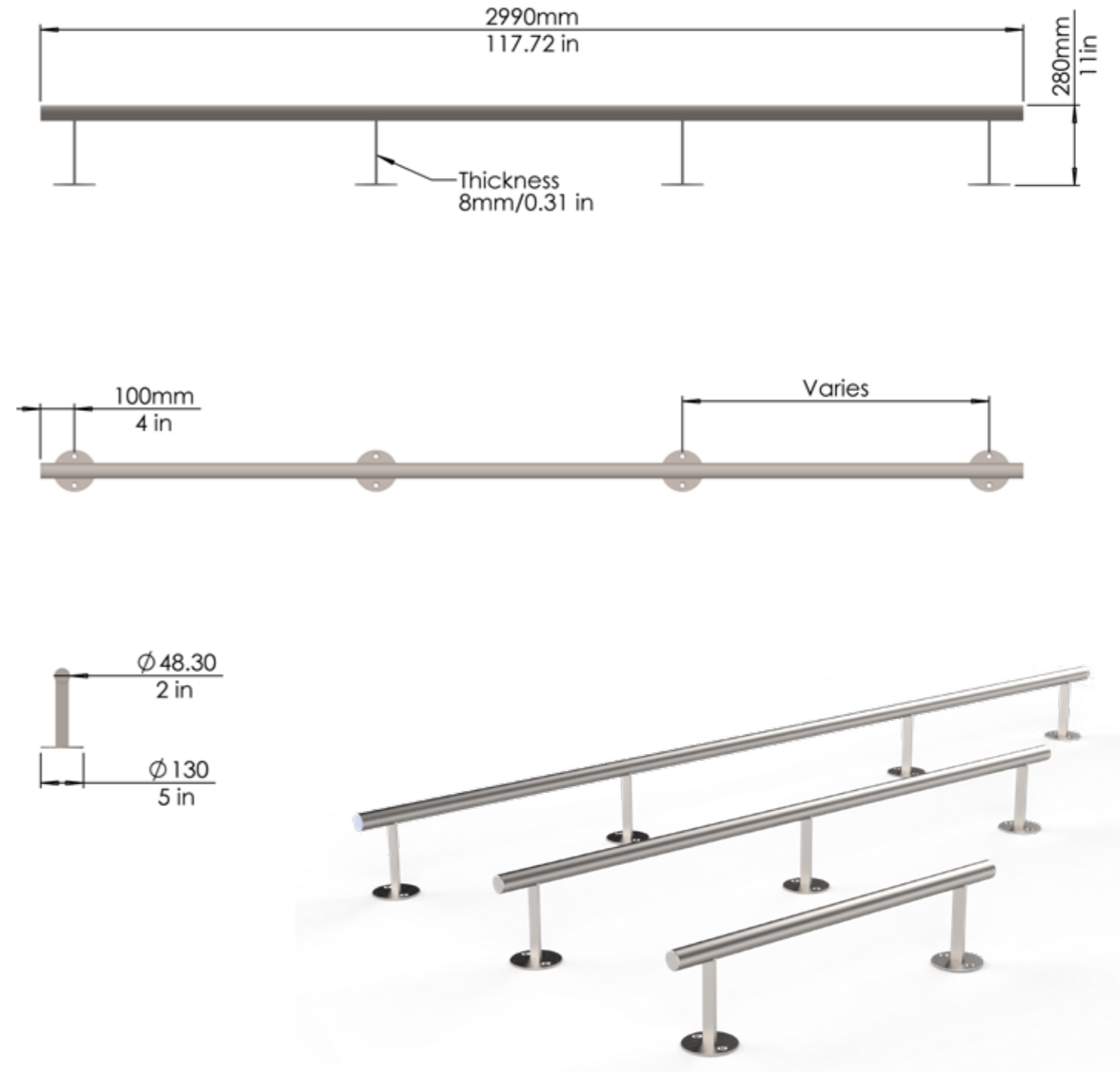

Optimal shipping length is 117.72" or 9.76' (2990mm) - custom lengths are regularly provided



Corner Section

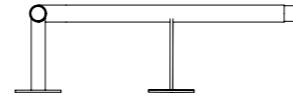
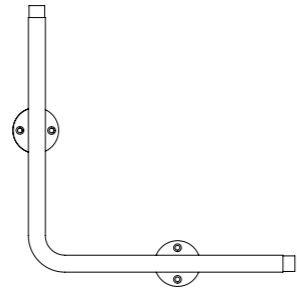

Append (CS) Kent Airport Bump Rail KABR 50 (CS) 90deg.
State Angle From 45deg. to 135deg.

Circle Column

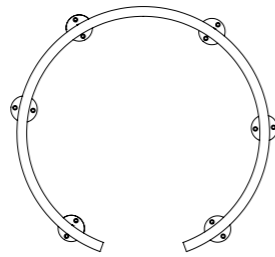

Append (CC) Kent Airport Bump Rail KABR 50 (CC) 78.74" (2,000mm).
State Diameter 39.37" (1,000mm) to 78.74" (2,000mm).

Square Column

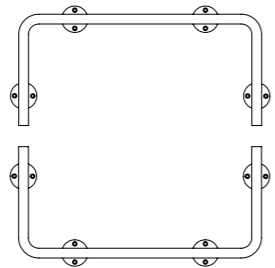

Append (SC) Kent Airport Bump Rail KABR 50 (SC) 39.37" (1,000mm) x 39.37" (1000mm).
State Length & Width 19.68" (500mm) to 39.37" (1,000mm).

U-Bend Section

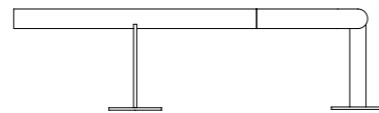
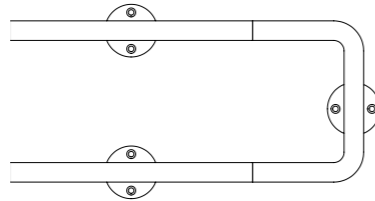

Append (UB) Kent Airport Bump Rail KABR 50 (UB) 9.84" (250mm).
State Width 9.84" (250mm) to 19.68" (500mm).



SPECIFY

Kent Airport Bump Rail (KABR-50): ▶ Grade 304L Stainless Steel; ▶ ASTM No. 6 Polish (EN10088 320 Grit Satin Finish); ▶ L: 117.72" (2990mm), H: 11" (280mm), Dia: 2" (48.3mm); ▶ 12GA (2.5mm Thick Steel); ▶ Visible Base Plate with Countersunk Fixings.

CHOOSE YOUR STEEL

Grade 304 Stainless Steel
Grade 316 Stainless Steel

CHOOSE YOUR FINISH

ASTM NO. 6 Polish
EN10088 320 Grit
Satin Finish

CUSTOMISE YOUR SIZE

or go with our standard
L: 117.72" (2990mm)
H: 11" (280mm)
Dia: 2" (48.3mm)

CHOOSE YOUR THICKNESS

14 gauge / 2mm
12 gauge / 2.5mm

CHOOSE YOUR FIXING

Visible Base Plate
or Buried Base Plate



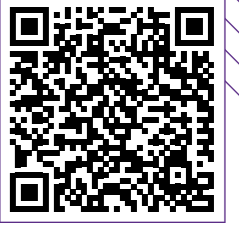

CLEANROOM WALL MOUNTED BUMP RAILS





Cleanroom Wall Mounted Bump Rail

Kent Stainless Cleanroom Wall Mounted Bump Rails are ideal for use on projects with floors with coved corners, especially vinyl or altro floors and when a floor mounted solution is best avoided. This wall version also means cleaners have access to the full floor area and are not impeded by leg supports. They have tubular wall mount supports and usually end with a blanked off end plate. At doorways or near corners this can be changed for a bollard end which is floor mounted. The bump rail is typically surface mounted on circular baseplates with acorn head (dome nut) fixings. As an option it can have countersunk fixings.

Small to Medium sized projects in the USA & Canada will ship from East Coast USA. Major international projects will ship from Ireland.

American projects are mostly made in the USA and made to imperial measures – typically a 2” dia tube. This same bump rail supplied to European projects would be supplied as a metric measure 48.3mm dia – rather than an exact conversion of 2” to 50.8mm. Approval drawings for each project will be supplied in imperial or in metric as requested and can be customised.

- FEATURES**
- 12GA (2.5mm) thick steel
 - ASTM No. 6 Satin Finish (USA)
 - EN10088 320 Grit Satin Finish (EU)
 - Grade 304L Stainless Steel as standard
 - 316L as an option
 - Circular Wall Plates with Dome Nut Fixings
 - Countersunk Fixings option available

- INDUSTRIES**
- Laboratories
 - Pharmaceutical
 - Hospitals
 - Medical Facilities
 - Biomedical

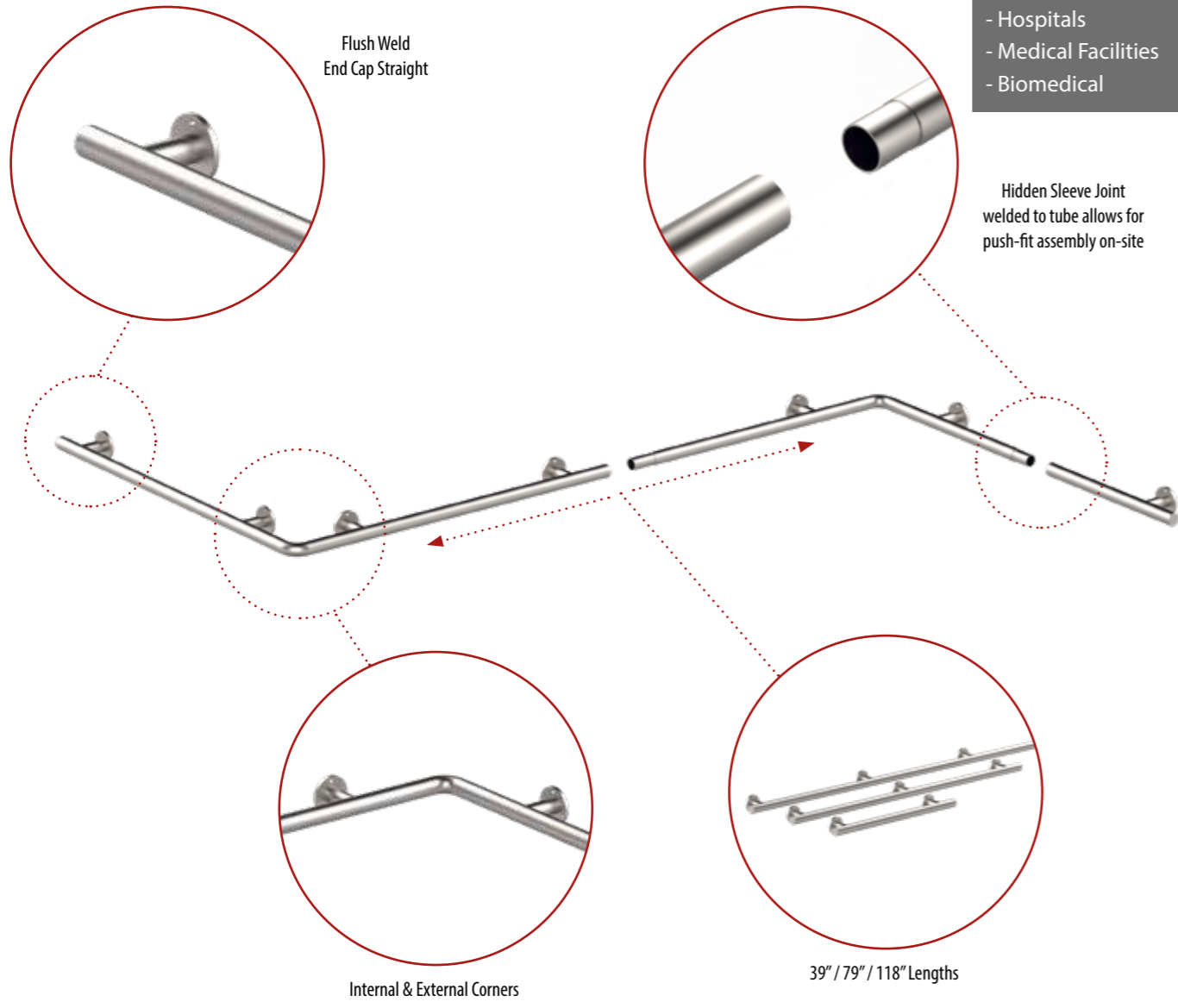

Product Code	Length	Offset	Diameter	
			USA	EU
Kent Cleanroom Wall Mount Bump Rail KWMBR-50	39.37" (1000mm)	4" (100mm)	2"	48.3mm
Kent Cleanroom Wall Mount Bump Rail KWMBR-50	78.74" (2000mm)	4" (100mm)	2"	48.3mm
Kent Cleanroom Wall Mount Bump Rail KWMBR-50	117.72" (2990mm)	4" (100mm)	2"	48.3mm

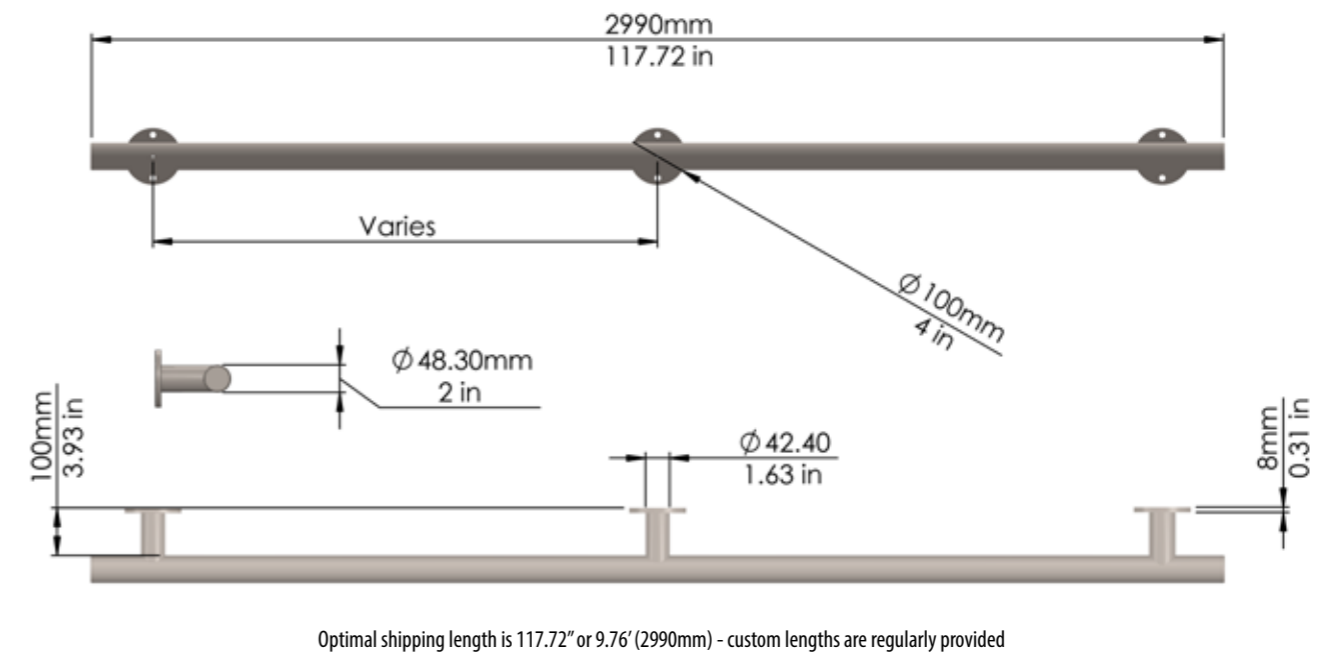

START/END OPTIONS





SPECIFY

Kent Cleanroom Wall Mount Bump Rail (KWMBR-50): ▶ Grade 304L Stainless Steel; ▶ ASTM No. 6 Polish (EN10088 320 Grit Satin Finish); ▶ L: 117.72" (2990mm), O: 4" (100mm). Dia: 2" (48.3mm); ▶ 12GA (2.5mm Thick Steel); ▶ Visible Wallplate with Dome Nut Fixings.



www.kentstainless.com/us

www.kentstainless.com



Made in USA



Made in Ireland

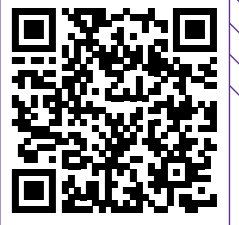

CLEANROOM WALL GUARDS



KENT STAINLESS
A PARTNER YOU CAN RELY ON



Cleanroom Wall Guard

Kent Cleanroom Wall Guards are designed primarily to protect insulated wall panels. Kent Wall Guards are fixed in place using wall mounted hidden brackets that are screwed into place on installation. The hidden fixings, along with a chamfered top and bottom ensure that there are no dirt trap and even lower rails are easy to clean. American projects are mostly made in the USA and made to imperial measures – typically 8” high. This same wall guard supplied to European projects would be supplied as a metric measure 200mm high – rather than an exact conversion of 8” to 203.2mm. Approval drawings for each project will be supplied in imperial or in metric as requested and can be customised.

- FEATURES**
- 14 Gauge (2mm) or 12 Gauge (2.5mm) thick steel
 - ASTM No. 6 Satin Finish (USA)
 - EN10088 320 Grit Satin Finish (EU)
 - Easy to maintain & clean
 - Grade 304L Stainless Steel as standard
 - No exposed fixings



Join Fixing Detail



Product Code	Length	Height		Thickness
		USA	EU	
Kent Cleanroom Wall Guard KWG 150/2	117.72" (2990mm)	6"	150mm	14 Gauge (2mm)
Kent Cleanroom Wall Guard KWG 200/2	117.72" (2990mm)	8"	200mm	14 Gauge (2mm)



SPECIFY

Kent Cleanroom Wall Guard (KWG 200/2): ▶ Grade 304L Stainless Steel; ▶ ASTM No. 6 Polish (EN10088 320 Grit Satin Finish); ▶ L: 117.72" (2990mm) , H: 8" (200mm); ▶ 14 Gauge (2mm) Thick Steel; Hidden Fixings.



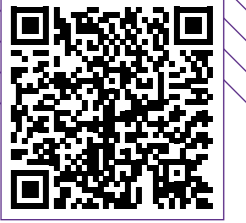

CLEANROOM CORNER GUARDS





Cleanroom Corner Guard

Kent Stainless Cleanroom Corner Guards are simple angled profiles – with 2” wings as standard. This can be customised to suit any size. They are adhered on by the contractor. The stainless steel used is 16GA (1.5mm for European projects) as standard but can be swapped out for 14GA (2mm) or 12GA (2.5mm) on request. Manufactured in USA for North American projects and Ireland for European projects. American projects are mostly made in the USA and made to imperial measures – typically 40” high with 2” wings. This same corner guard supplied to European projects would be supplied as a metric measure 1000mm high with 50mm wings – rather than an exact conversion of 40” to 1016mm and 2” to 50.8mm. Approval drawings for each project will be supplied in imperial or in metric as requested and can be customised.

- FEATURES**
- 16GA (1.5mm) as standard
 - ASTM No. 6 Satin Finish (USA)
 - EN10088 320 Grit Satin Finish (EU)
 - Grade 304L Stainless Steel as standard

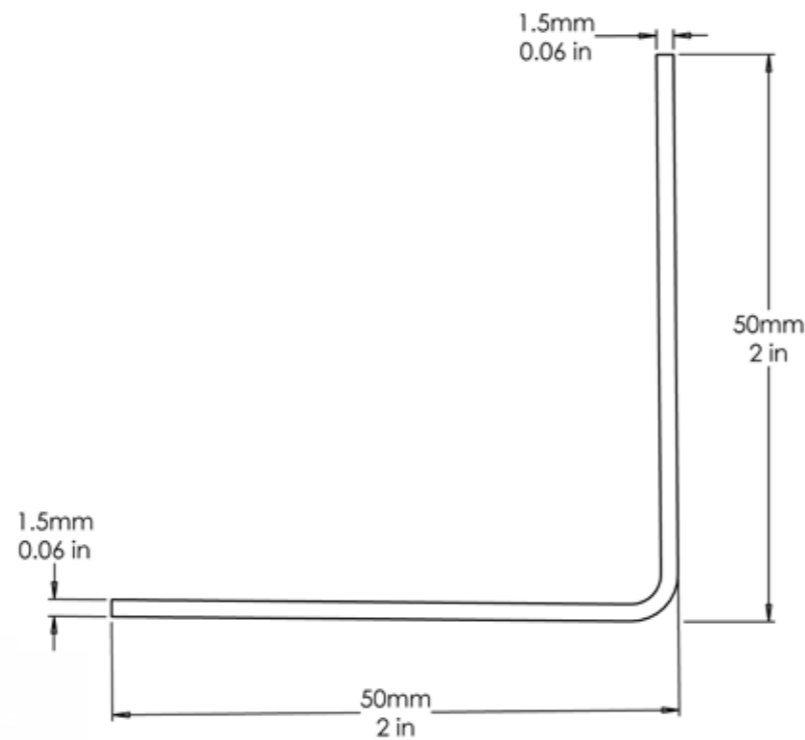

Product Code	Length		Wing A		Wing B	
	USA	EU	USA	EU	USA	EU
Kent Cleanroom Corner Guard KCG 50	40"	1000mm	2"	50mm	2"	50mm

SPECIFY

Kent Cleanroom Corner Guard (KCG50): ▶ Grade 304L Stainless Steel; ▶ ASTM No. 6 Polish (EN10088 320 Grit Satin Finish) for European projects; ▶ L: 40" (1000mm), A: 2" (50mm), B: 2" (50mm); ▶ T: 16GA (1.5mm) thick steel.



Maintenance of Stainless-Steel

Clean the stainless-steel components using warm water with a mild detergent with a nonabrasive cloth or sponge. Heavier stains may require the use of a nylon-scouring pad or a stainless-steel cleaner. To remove paint or graffiti use a cloth and Alkaline or solvent paint strippers according to type of paint. In the case of a bead blasted finish, where abrasive cleaning is required, always use a random circular rubbing action with a cloth. In the case of brushed finishes, the surface consists of uniform fine 'scratches' running in one direction so where abrasive cleaning is required always use a straight back and forward rubbing action in the direction of the grain using soap and warm water. Rust spots or 'tea stains' can occur on the surface of the material, these are normally caused by contamination from ordinary mild steel, particularly in areas where construction work has been undertaken. Such stains can be removed using Rust Remover 410. In cases where the surface is severely stained because of severe environmental conditions or scratched due to misuse, it may still be possible to restore the original finish using chemicals such as Oxalic Acid solution. There are many stainless-steel polishes available to enhance the surface finish.



CLEANROOM FLAT BAR CRASH RAIL

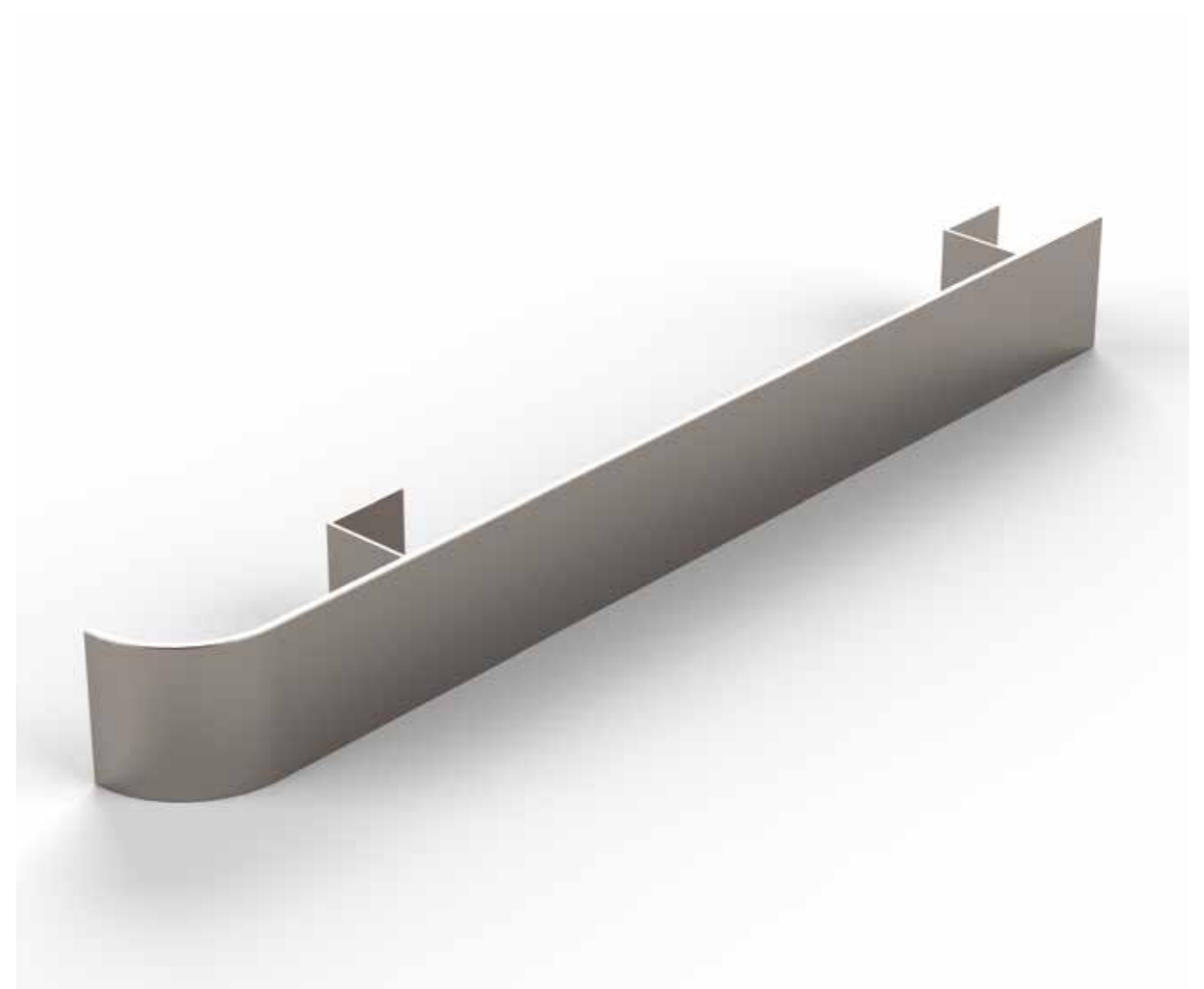



Cleanroom Flat Bar Crash Rail

Kent Stainless Cleanroom Flat Bar Crash Rail is an alternative to our Wall Guard range and complements our Corner Guards and Tubular Bump Rail.

This Cleanroom style Flat Bar Crash Rail is typically supplied mounted on 3" Z Brackets with invisible front fixings - a welded stub to the rear of the crash rail is mechanically fixed to the Z Bracket. The standard offset from the wall is 3", but we can accommodate any offset desired from 1-1/2" beyond.

The brackets have 4 perforations—of which 2 are required to connect to the wall. The remaining 2 are useful in case of a clash with steel partition fixings. Also, this Z bracket is reversible allowing the 2 or 4 fixings to be made on the opposite side.

Manufactured and shipped from east coast USA.

FEATURES

- 1/4" Thick Flat Bar (6mm)
- ASTM No. 4 Satin Finish (USA)
- EN10088 320 Grit Satin Finish (EU)
- Z Brackets
- Grade 304L Stainless Steel as standard
- 316L as an option

INDUSTRIES

- Laboratories
- Pharmaceutical
- Hospitals
- Medical Facilities
- Biomedical

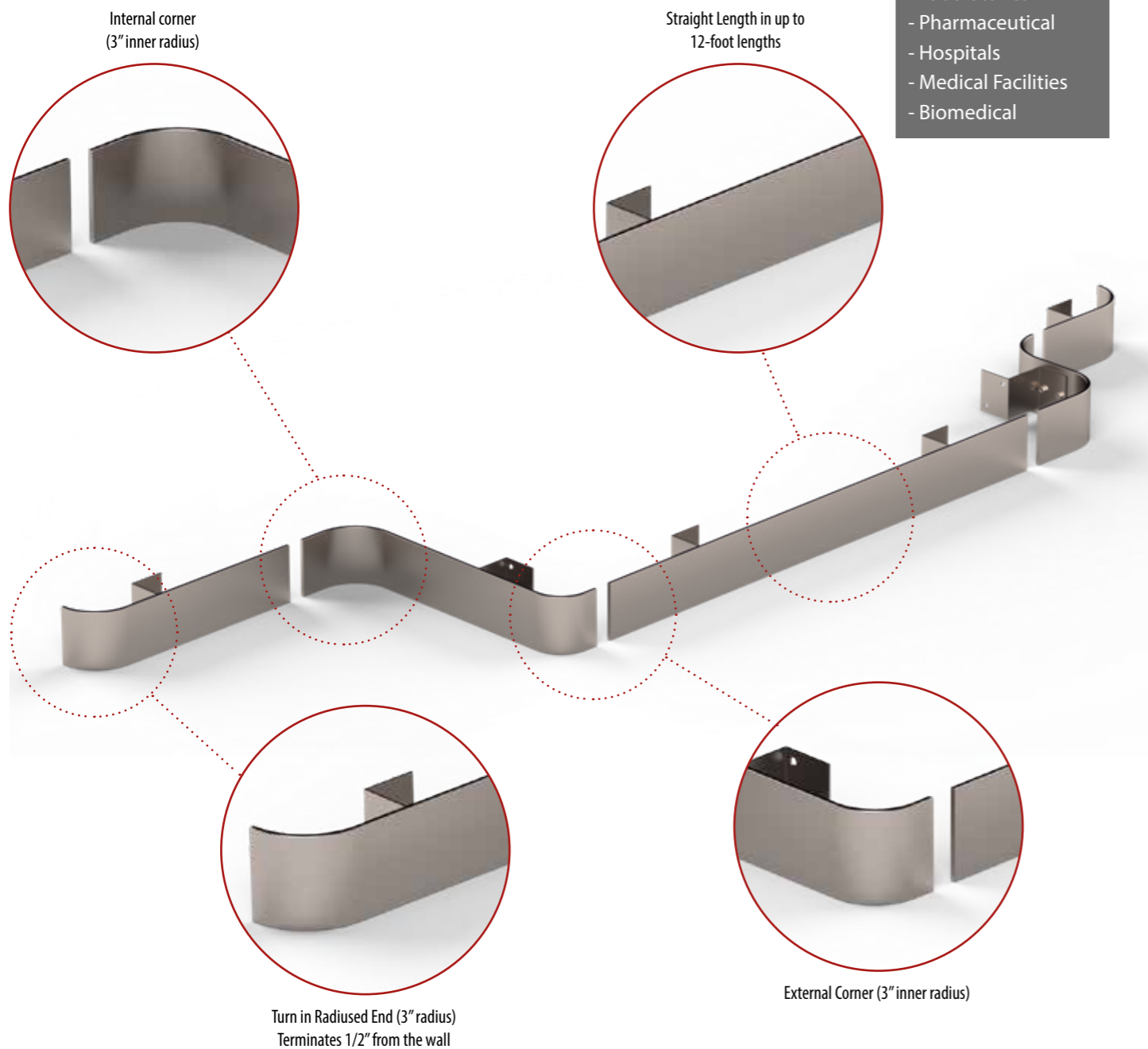

Product Code	Thickness	Height	Bracket Offset
Cleanroom Flat Bar Crash Rail KCCR102/5/76	1/4" (6mm)	4" (102mm)	3" (75mm)
Cleanroom Flat Bar Crash Rail KCCR76/6/76	1/4" (6mm)	3" (76mm)	3" (75mm)
Cleanroom Flat Bar Crash Rail KCCR152/6/76	1/4" (6mm)	6" (152mm)	3" (75mm)

4" high rails are our standard product but can be customised. Maximum distance between mounting brackets is 4 foot, but can be reduced to 1 foot. A short length up to 10 inches can be mounted on 1 bracket.



Hygienic Invisible Fixings—stubs welded to rear of flat bar allow completely smooth finish to front face.



Z Bracket can be reversed to help avoid clashes with services behind drywall. Z Bracket requires 2 fixings through to dry wall at rear. Kent supplies this back plate with 4 perforations of which only 2 are required—allowing flexibility when installing. (1 fixing from the top row and 1 from the bottom row must be used as a minimum)

SPECIFY

Kent Cleanroom Crash Rail (KCCR102/6/76): ▶ Grade 304L Stainless Steel; ▶ No. 4 Finish; ▶ L:10'; H: 4"; Z: 3"; ▶ Thickness 1/4"; Invisible Fixings.



INTERNAL CLEANROOM BOLLARDS





Internal Cleanroom Bollard

Kent Stainless Internal Cleanroom Bollard is ideal for Life Science projects - Pharmaceutical Factories, Laboratories, Hospitals. The standard 4" dia version stands at 40" high with hidden fixings. It's grade 304/316 Stainless Steel material along with its no. 6 satin finish makes it super hygienic. American projects are mostly made in the USA and made to imperial measures - typically 40" high. This same bollard supplied to European projects would be supplied as a metric measure 1000mm high - rather than an exact conversion of 40" to 1016mm. Approval drawings for each project will be supplied in imperial or in metric as requested and can be customised.

- FEATURES**
- 11GA (3mm) thick steel
 - ASTM No. 6 Satin Finish (USA)
 - EN10088 320 Grit Satin Finish (EU)
 - Hidden fixings
 - Grade 304L or 316L Stainless Steel
 - Fixings included

- INDUSTRIES**
- Laboratories
 - Pharmaceutical
 - Hospitals
 - Medical Facilities
 - Biomedical

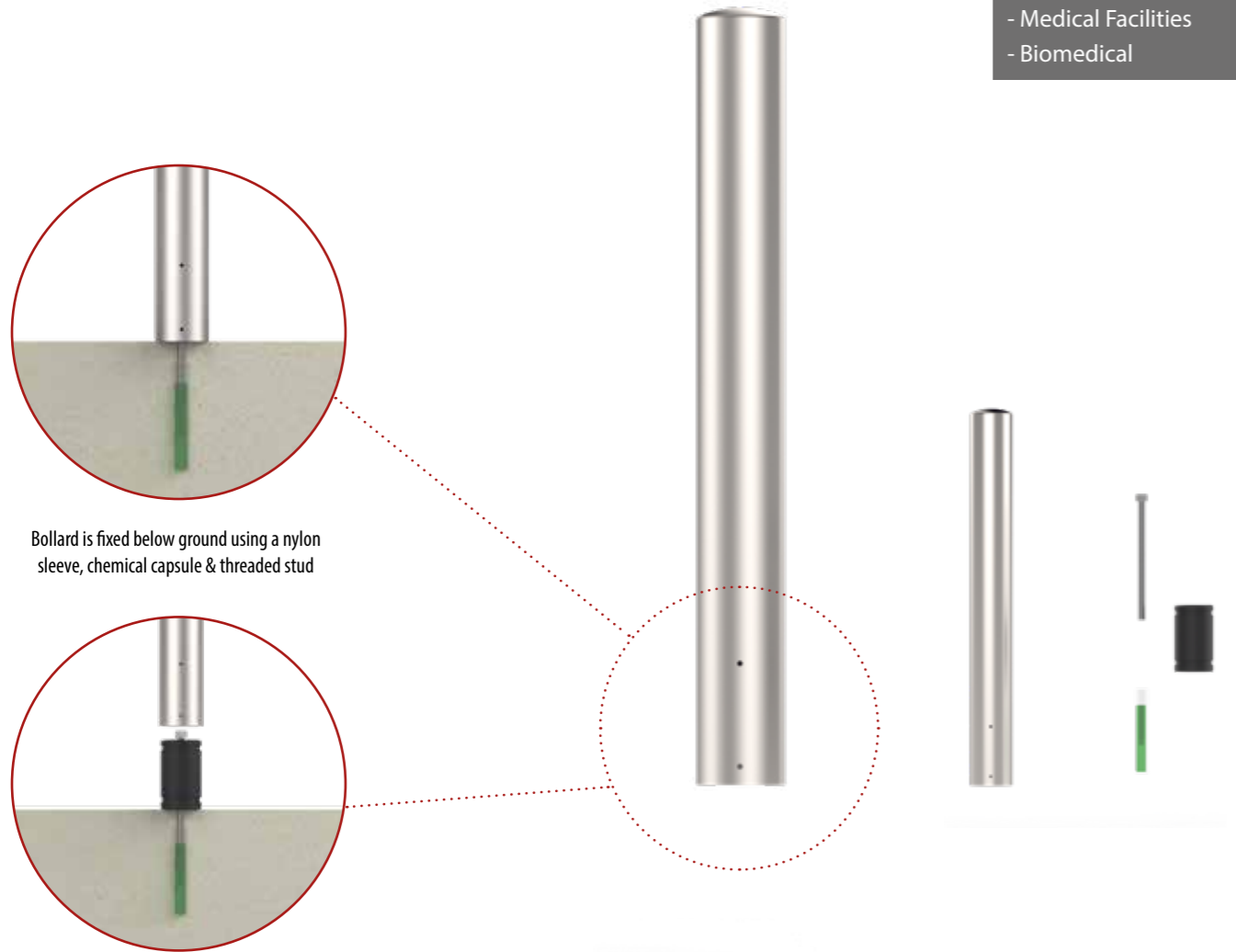

Bollard is fixed below ground using a nylon sleeve, chemical capsule & threaded stud



Product Code	Height		Diameter	
	USA	EU	USA	EU
Kent Internal Cleanroom Bollard KICB-114	40"	1000mm	4"	114mm
Kent Internal Cleanroom Bollard KICB-168	40"	1000mm	6"	168mm

SPECIFY

Kent Internal Cleanroom Bollard (KICB-114): ▶ Grade 304L Stainless Steel; ▶ ASTM No. 6 Polish (EN10088 320 Grit Satin Finish) for European projects ▶ H: 40" (1000mm), Dia: 4" (114mm), 11 GA (3mm) Thick Steel; ▶ Internal Hidden Fixings; Dome Top.





INTERNAL FACTORY BOLLARDS

Internal Factory Bollard

Kent Stainless Internal Factory Bollard is ideal for Food Factories or in Life Science construction projects.

The Standard 4" (114mm) dia version stands at 40" (1000mm) high with a surface mounted base plate. It's made form grade 304 stainless as standard with a No. 6 finish. Small to Medium sized projects in the USA & Canada will ship from East Coast USA. Major international projects will ship from Ireland.

American projects are mostly made in the USA and made to imperial measures – typically 40" high. This same bollard supplied to European projects would be supplied as a metric measure 1000mm high – rather than an exact conversion of 40" to 1016mm. Approval drawings for each project will be supplied in imperial or in metric as requested and can be customised.

- FEATURES**
- 11GA (3mm thick steel)
 - ASTM No. 6 Satin Finish (USA)
 - EN10088 320 Grit Satin Finish (EU)
 - Visible Baseplate with Dome Nuts version as standard
 - Optional Cover Cowl to hide fixings
 - Grade 304L Stainless Steel as standard
 - Fixings included

- INDUSTRIES**
- Laboratories
 - Pharmaceutical
 - Hospitals
 - Medical Facilities
 - Biomedical
 - Food Processing
 - Rail Terminals
 - Airport Terminals



7.87" (200mm) diameter Base Plate fixed on ground level with Dome Nuts



KENT STAINLESS
A PARTNER YOU CAN RELY ON

www.kentstainless.com/us
 Made in USA

www.kentstainless.com
 Made in Ireland

Product Code	Height		Diameter	
	USA	EU	USA	EU
Kent Internal Factory Bollard KIFB-114	40"	1000mm	4"	114mm
Kent Internal Factory Bollard KIFB-168	40"	1000mm	6"	168mm

SPECIFY

Kent Internal Factory Bollard (KIFB-114): ► Grade 304L Stainless Steel; ► ASTM No. 6 Polish (EN10088 320 Grit Satin Finish) for European projects ► H: 40" (1000mm), Dia: 4" (114mm), 11GA (3mm) thick steel; ► Visible Dome Fixings; Dome Top.



SURFACE PROTECTION & INTERNAL DRAINAGE

UNITED STATES OF AMERICA & CANADA

USA - WEST COAST

Internal Drainage

Gilead Life Sciences - La Verne, CA
Stanford University - San Jose, CA
Tri-Cities Animal Control Facility - Pasco, WA

Surface Protection

Agenus - Emeryville, CA
Amgen - Thousand Oaks, CA
Allergan - Irvine, CA
Genentech - San Francisco, CA
Ocean View Hotel - Santa Monica, CA
ThermoFisher - Fremont, CA

CANADA

Internal Drainage

Bombardier - Toronto, ON
Cowichan Hospital - Duncan, BC
Dalton Pharma - Toronto, ON
Estee Lauder - Toronto, ON
GSK - Mississauga, ON
Novocol Pharma - Cambridge, ON
Sanofi Pasteur - Toronto, ON

Surface Protection

Moderna - Laval, QC

USA - EAST COAST

Internal Drainage

Allegheny General Hospital - Pittsburgh, PA
AstraZeneca - Gaithersburg, MD
Bayer - Cambridge, MA
Beam Therapeutics - Durham, NC
Bristol Myers Squibb - Waldwick, NJ
Cornell University - Ithaca, NY
Harrison C&S Lab - Salem, NH
Hovione - East Windsor, NJ
Kedrion Biopharma - Melville, NY
Lotte Biologics - East Syracuse, NY
Merck - Rahway, NJ
Novavax - Elkridge, MD
O'Hare International Airport - Chicago, IL
Ology Bioservices - Gainesville, FL
Ortec - Greenville, SC
Pall Pharmaceuticals - Duncan, SC
Sanofi Pasteur - Swiftwater, PA
Spark Therapeutics - Philadelphia, PA

Surface Protection

Abzena - Sanford, NC
AstraZeneca - Bensalem, PA
Beam Therapeutics - Braintree, MA
Janssen - Malvern, PA
JFK Airport - Queens, NY
LeMaitre Vascular - Burlington, MA
Moderna - Norwood, MA
NIH - Elkridge, MD
Vertex Manufacturing Centre - Portsmouth, NH

USA - CENTRAL

Internal Drainage

Abbott - Kenosha, WI
Eli Lilly - Indianapolis, IN
FLW Hospital - Fort Leonard Wood, MO
GSK - Hamilton, MT
Millipore HPAPI - Madison, WI
Merck Animal Health - Omaha, NE
Phibro AH - Omaha, NE
Shamrock Tower - Kansas City, MO

Surface Protection

Banner University Medical Center - Phoenix, AZ
CVG Airport - Hebron, KY
Lorenzo Hotel - Dallas, TX
New Orleans Airport - New Orleans, LA



Product Range

Cleanroom Fitout

Surface Protection

Street Furniture

Heelproof Ventilation Grilles

Power Distribution

Drainage

Dewatering Machinery

Access Covers & Manholes

Process Waste Tanks

www.creativedesignandprint.ie TEL 053 914 4264

Kent Stainless Ltd

Ardcavan, Wexford, Y35 CRW2, Ireland.

TEL NO + 353 53 914 3216 | UK FREEPHONE 0800 376 8377 | USA 781 374 7391

WEB www.kentstainless.com | EMAIL info@kentstainless.com

KENT STAINLESS
A PARTNER YOU CAN RELY ON